

Thank you for purchasing this high quality Banlaw product. Please read through and understand the information in this Product Data Sheet before installation or operation to avoid potential health safety and environment (HS&E) risks or equipment damage.



Figure 1 - BFCV23



Figure 2 – BFTFCV43

1 PRODUCT DESCRIPTION

The range of **Banlaw FillSafe™ Zero** overfill protection (OFP) systems is designed for the safe and reliable refuelling/refilling of diesel fuel tanks, commonly used in the mining, rail, port, construction and other off-road industries. The system comprises two (2) major assemblies;

- Banlaw Flow Control Valve (e.g. BFCV23 model);
 - Each Valve assembly includes a Receiver Dust Cap.
- Banlaw Level Sensor (e.g. BVLS model);
 - Refer applicable documentation (e.g. PSG, PDS) for information on the range of FillSafe Zero Level Sensors.

This document covers the 23 and 43 series Flow Control Valves. Please refer to separate Banlaw documentation for detailed information on other FillSafe Zero system products.

The 23 Series Flow Control valves suit the Banlaw 800 Series range of Mining and Rail Series Dry-Break Nozzles. The Mining Series valve will also suit many industry standard dry-break refuelling nozzles. The Rail Series Flow Control Valve will only suit the Banlaw Rail Series nozzle.



The 43 Series Flow Control Valves suit the Banlaw 1000 Series Dry-Break Nozzle only.

CONTENTS

1	PRODUCT DESCRIPTION.....	1
2	IMPORTANT RESTRICTIONS ON THE USE OF THIS PRODUCT.....	3
3	GLOSSARY OF ACRONYMS.....	5
4	PRODUCT SPECIFICATIONS.....	6
5	KEY FEATURES AND TYPES.....	7
5.1	Cold Temperature Model Variants.....	8
5.2	Banlaw FuelTrack™ Model Variants.....	8
5.3	Part Number, Serial Number and FuelTrack Marking.....	9
6	KEY ADVANTAGES OF BANLAW FILLSAFE™ FLOW CONTROL VALVES.....	10
7	PRINCIPLES OF OPERATION.....	11
8	INSTALLATION & COMMISSIONING GUIDELINES.....	16
8.1	Pre-Installation Guidelines.....	16
8.2	External Pilot Lines.....	18
9	INSTALLATION PROCEDURE.....	19
10	COMMISSIONING PROCEDURE.....	20
11	REFUELLING OPERATION SEQUENCE.....	24
12	MAINTENANCE & SPARE PARTS.....	25
13	PREVENTATIVE MAINTENANCE.....	27
13.1	Banlaw Site Service and Preventative Maintenance.....	28
14	TROUBLESHOOTING.....	29
15	PRODUCT RECYCLING & DISPOSAL.....	31
16	PRODUCT WARRANTY.....	31

2 IMPORTANT RESTRICTIONS ON THE USE OF THESE PRODUCT

The terms Warning, Caution and Note may be used in this document in the following context:

	<p>Information given with the WARNING icon must be considered to avoid serious injury.</p>
	<p>Information given with the CAUTION icon must be considered to avoid damage to equipment and possible injury.</p>
	<p>Information given with the NOTE icon is highlighted to assist with a process or action. It may emphasise or add to other text in the document</p>

CAUTION	
	<p><i>The content of this document is <u>not</u> meant to override or substitute any applicable Statutory, Regulatory, Customer/Site, etc. Health Safety & Environment (HS&E) requirements.</i></p>
	<p><i>All works should only be performed by trained, qualified and competent personnel who are aware of the hazards associated with the constituent components of this installation in addition to the system as a whole. Failure to comply with these practices may result in death, serious bodily injury, loss of equipment and environmental damage.</i></p>
	<p><i>A risk assessment (job hazard analysis - JHA) should be conducted PRIOR to the start of any works or actions within this document. Whilst every effort has been made to ensure the execution of this document represents no HS&E hazard, Banlaw takes neither responsibility nor liability for the consequences and damages that may occur in the execution of works within this document.</i></p>
	<p><i>Persons conducting or otherwise involved with the execution of the works within this document and project have an obligation to ensure that all HS&E requirements are known and understood, and subsequently followed at all times.</i></p>

WARNING
DANGER

1. The safe installation and subsequent operation of a Banlaw product relies on the completion of all necessary **"due diligences"** for the assessment of the Banlaw product(s) being suitable for the intended application(s). Such an assessment is best achieved through the mutual cooperation of the supplier/OEM (Banlaw) and the customer or end-user. Once such an assessment deems the Banlaw product(s) to be suitable, the customer or end-user shall ensure effective **"change management"** applies should any prominent or influential aspect of the application (upon which the initial assessment was based) be subject to change and may affect the ongoing suitability (i.e. safety and proper function) of the Banlaw product.
2. The Banlaw FillSafe™ Zero Flow Control Valves incorporate components manufactured from **aluminium**. Products containing **external (exposed) aluminium** are typically unsuitable for use within an underground coal mine, or otherwise within an area where the use of external aluminium components (or other materials within the product) are prohibited for use in such areas in accordance with applicable governances.

CAUTION



1. Unless noted otherwise by Banlaw, the Banlaw FillSafe™ Zero tank overflow protection (OFP) system has not been assessed under any Regulatory or Industry Standard, Code, Directive, Guideline or other governance which may apply to the use of this product in applications where a governance applies. Please consult Banlaw prior to installation if in doubt.
2. The male refuelling coupling (refuelling nozzle adaptor, or fuel "receiver") fitted to the front of a Banlaw FillSafe™ Zero Flow Control Valve must only be used (connected with) a compatible nozzle. No alternative nozzle, fluid coupling or other attachment should be used with this product.
3. The Banlaw FillSafe™ Zero system is designed for use only with clean (i.e. filtered) automotive grade diesel fuels, including commercial bio-diesel blends. This Banlaw product is not recommended for use with waste diesel fuel, or with diesel fuel containing contamination levels beyond those stipulated by governances and guidelines such as the current Worldwide Fuel Charter (WWFC) and fuel quality requirements of modern diesel engine manufacturers. The use of this product with fuel of higher contamination levels may cause the improper operation (failure) of the product and other detrimental effects. Banlaw recommends adequate fuel contamination controls (e.g. filtration) for all fuels passing through the Banlaw FillSafe™ Zero system.
4. Specifically for Cold Temperature model Valves, noticeable physical changes (e.g. clouding, additive drop-out, agglomeration, thickening, etc.) of the diesel fuel passing through the Valve may cause reduced functionality of the Valve and the FillSafe Zero OFP system.

Note:



This product is unsuitable for use with AdBlue (DEF) or with an alternative fluid (or substance) whose properties may affect the safety, function or reliability of the product. Please consult with Banlaw to confirm fluid compatibility if in doubt.

3 GLOSSARY OF ACRONYMS

The following acronyms are used in this document:

Acronym	Meaning
HMI	Human Machine Interface
OFP	Over Fill Protection
FMS	Fuel Management System
SFL	Safe Fill Level
TLS	Tank Level Switch
SWP	Safe Working Pressure, Maximum recommended
LPM	Litres per minute (volumetric flowrate)
GPM	US Gallons per minute (volumetric flowrate)
Max.	Maximum (upper limit)
Min.	Minimum (lower limit)
JHA	Job Hazard Analysis

4 PRODUCT SPECIFICATIONS

Operating Temperature (°C / °F) – Standard Series	-10°C (14°F) < T°C < 55°C (131°F)
Operating Temperature (°C / °F) – Cold Temp Series	-51°C (-60°F) < T°C < 55°C (131°F)
23 Series Flow Rate Range (LPM/GPM)	200LPM/53GPM < Flow Rate < 800LPM/211GPM
43 Series Flow Rate Range (LPM/GPM)	400LPM/106GPM < Flow Rate < 1000LPM/211GPM
Compatible Fluid Types	Clean (filtered) automotive grade diesel fuels , including commercial bio-diesel blends.
Safe Working Pressure	2500kPa / 363psi
Installation Thread Sizes	4" NPT(M), ¾" JIC(M)
Maximum Angle of Operation	±45° either side of the horizontal plane
External Pilot Line	Diesel Fuel Rated DN12 hose, 0-10m (33') max length
Connection Type 23 Mining Series	Banlaw 800 Mining Series dry-break diesel refuelling Nozzles and other industry standard nozzles.
Connection Type 23R Rail Series	Banlaw 800 Rail series dry-break diesel refuelling Nozzles only.
Connection Type 43 Series	Banlaw 1000 Series dry-break diesel refuelling Nozzles only.
Primary Material Construction	Zinc Plated Steel, Aluminium, Brass, Stainless Steel, Viton®, Fluorosilicone, Acetal, Nylon (23 series Dust Cap)
Seal Type – Standard Series	Viton® (FKM/FPM)
Seal Type – Cold Temp Series	Fluorosilicone
Installation Tool	Socket (90mm x 1" AF Hex) Socket, Banlaw Part No: BFCVSOCKET

- Notes:** 1. All pressure data refers to the **internal** fluid gauge pressure, where each product is in "as new" condition.
2. The core function of Cold Temperature model valves have been tested by an independent laboratory at -51°C (-60°F). These Valves are fitted with fluid seals rated for operation below -60°C (-76°F).

5 KEY FEATURES AND TYPES

The important subassemblies and features of the Flow Control Valves are illustrated in Figure 3. The current generation valves also incorporate a **rotating collar** to allow the Pilot Line port to be best oriented (positioned) after the valve is installed. This useful feature allows the installer to comfortably thread the valve into a 4" NPT(F) port without trying to over or under tighten the valve to point the pilot line outlet in any particular direction.

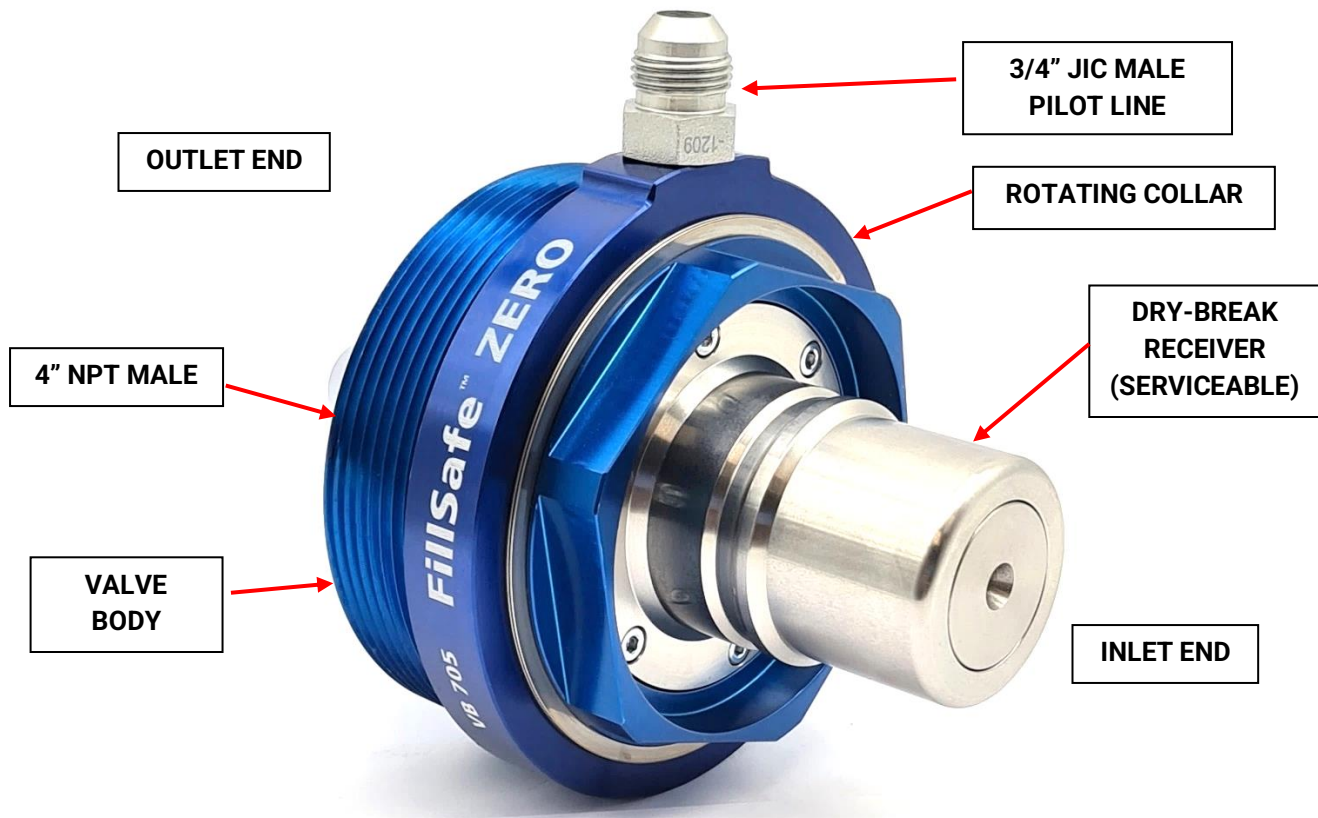

Figure 3 - Key Features of the Flow Control Valve Assembly (Receiver Dust Cap not shown)

This document covers the following separate Flow Control Valve assemblies (including their Cold Temperature variants);

- **BFCV23**; standard “mining” spec flow control valve assembly. Receiver suits Banlaw “mining” dry-break refuelling nozzles, e.g. Banlaw **BNM800** model, and other “industry compatible” nozzles.
- **BFCV23R**; standard “railway” spec flow control valve assembly. Receiver suits only Banlaw “rail” dry-break refuelling nozzles, e.g. Banlaw **BNR800** model.
- **BFTFCV23**; Banlaw FuelTrack™ “auto ID” mining spec flow control valve assembly. Receiver incorporates passive electronic ID “tag” to suit Banlaw **FuelTrack™** dry-break “mining” refuelling nozzles, e.g. Banlaw **BNMF800** model.
- **BFTFCV23R**; Banlaw FuelTrack™ “auto ID” rail spec flow control valve assembly. Receiver incorporates passive electronic ID “tag” to suit only Banlaw **FuelTrack™** dry-break “rail” refuelling nozzles, e.g. Banlaw **BNRF800** model.
- **BFCV43**; standard spec flow control valve assembly. Receiver suits only Banlaw 1000 series refuelling nozzles, e.g. **BN1000** model.
- **BFTFCV43**; Banlaw FuelTrack™ “auto ID” spec flow control valve assembly. Receiver suits only Banlaw FuelTrack™ 1000 series dry-break refuelling nozzles, e.g. **BNF1000** model.

5.1 Cold Temperature Model Variants

Cold Temperature (extreme cold temperature climate) Valve assemblies incorporate the suffix “-CT” in the part number, e.g. BFCV23-CT. All Valve assemblies are supplied with a Receiver Dust Cap. Cold Temperature nozzles use Fluorosilicone seals which is a softer elastomer at a moderate room temperature compared to Viton which is used in the standard valve variants. Fluorosilicone is best for use in very low temperature conditions where the softer material will harden to act more like Viton. Although Fluorosilicone will seal in hotter more temperate regions, the softer material properties will lead to accelerated wear and abrasion. For this reason Banlaw recommends the “-CT” variants for cold temperature regions, and the standard Viton seal variants for warmer conditions.

5.2 Banlaw FuelTrack™ Model Variants

Banlaw FuelTrack™ model variants allow for the automatic identification of the asset being refuelled when incorporated into the greater Banlaw ResTrack™ system. With a FuelTrack model Flow Control Valve the operator is able to perform a refuelling action without worrying about pressurising the fuel tank or manually recording the fuel transaction, making the Banlaw FuelTrack™ integrated Flow control Valves unique without peer.

Figure 4 illustrates a standard dry-break receiver (front end) compared with a FuelTrack “Auto ID” receiver.

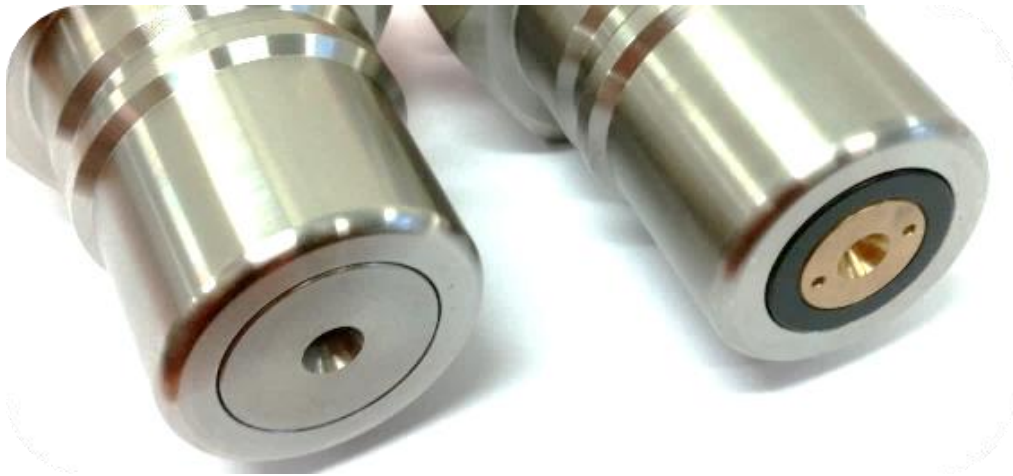

Figure 4 - "Standard" Receiver (left) and FuelTrack "Auto ID" Receiver (right).

5.3 Part Number, Serial Number and FuelTrack Marking

The part number for a valve is marked on each assembly.

Each valve assembly is assigned a unique manufacturing serial code – refer Figure 5.



Figure 5 - Serial Code Marking Location.

Banlaw FuelTrack™ Valves are marked with the Auto-ID “tag” (code) unique to the assembly. This code is stamped to the receiver body and not to the main valve as the receiver may be replaced independently of the valve. This ID tag code must be registered within the Banlaw ResTrack™ fuel management system used onsite to authorise diesel fuel to be issued into plant equipment on which a FuelTrack Flow Control Valve is installed.

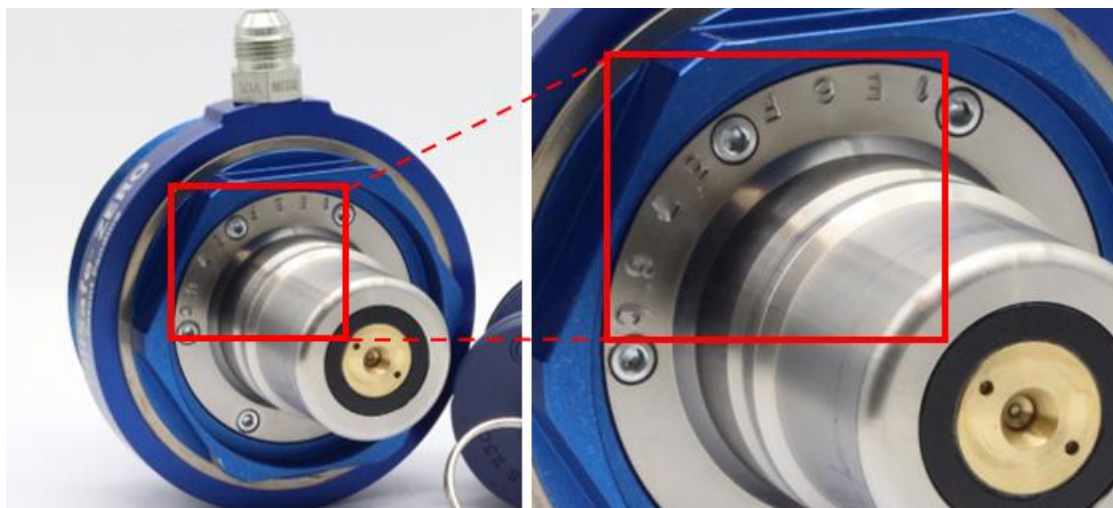

Figure 6 - Banlaw FuelTrack™ Code Location.

6 KEY ADVANTAGES OF BANLAW FILLSAFE™ FLOW CONTROL VALVES

- **Stainless steel** receiver body, providing superior durability and corrosion resistance.
- Unlike some Receiver and Flow Control Valve combinations, the Banlaw Dry-Break Receiver (front end) and Flow Control Valve (rear end) have been **designed as a unitary assembly**, meaning the internal flow path through the Flow Control Valve assembly has been optimised to provide **lower resistance to fuel flow, increased flow efficiency, and reduced incidence of premature shut-off** of the mating dry-break refuelling nozzle.
- Only a single fuel pilot (signal) line is required to connect the FillSafe Zero Flow Control Valve and Level Sensor assemblies.
- Unique (patented and patents pending) rotating collar allows the Pilot Line port to be oriented (positioned) as desired once the Valve has been installed.
- The option of either a Banlaw “non-venting” Level Sensor (i.e. BLS model) or “venting” Level Sensor (i.e. BVLS model) via an **external** Pilot Line.
- The Valve assembly may be installed directly to the tank inlet port or remote from the tank inlet, provided the overall length of the Pilot Line and the vertical distance (height) between the Valve and the Level Sensor do not exceed the limitations as set out in the Pilot Line guidelines.
- May be used with non-Banlaw (third party) Level/Float Sensors – please contact Banlaw for advice **prior** to installation of a Banlaw Valve.
- BFT (auto ID) variants available to suit the **Banlaw ResTrack™ Fuel and Resource Management Systems**.
- **Cold Temperature** variants rated for operation down to -51°C (-60°F);
 - Basic function of the Valve tested by an independent (third party) test laboratory at -51°C (-60°F).

These valve assemblies incorporate 2 separate and independent means of diesel flow control;

- Normally closed (N/C) Receiver Poppet (front of Valve assembly);
 - Mechanically displaced into the open position upon actuation of the mating dry-break nozzle into the ON (open) position.
 - Returns to the N/C position upon actuation of the mating dry-break nozzle into the OFF (closed) position.
- Flow Control Valve Piston (within Valve Body);
 - Open and closed status actuated by fuel flow (pressure).
 - Piston forced into the closed position upon actuation of the Level Sensor used in conjunction with the Valve assembly (specifically closure of the fuel trickle flow from the Valve to the Level Sensor via the Pilot Line).
 - The Flow Control Valve is not designed nor intended to act as a non-return (check) valve to prevent the discharge of fuel from the tank via the Receiver.

7 PRINCIPLES OF OPERATION

The principal function of a Flow Control Valve is to work in unison or in communication with a Banlaw FillSafe™ **Level Sensor** via a Pilot Line. Figure 7 shows an example of a basic FillSafe Zero system.



Figure 7 - Basic Arrangement of a FillSafe Zero System

Figure 8 illustrates an example of a FillSafe Zero “venting” Level Sensor – BVLS80 – compatible with this Flow Control Valve. Figure 9 illustrates an example of a FillSafe Zero “non-venting” Level Sensor – BLS200B – also compatible with this Flow Control Valve. In both instances, the Flow Control Valve is connected to the Level Sensor via a Pilot Line routed **externally** (outside) the tank. There is no internal Pilot Line option is available with the range of 4” Valves.



Figure 8 - Example of a Banlaw "Venting" Level Sensor (BVLS80 shown on its side)



Figure 9 - Example of a Banlaw "Non-Venting" Level Sensor (BLS200B shown on its side)

Under normal operation, there are **2 operating states** of a FillSafe Zero system;

1. Tank Filling;

- a. Level Sensor float valve “open”.
- b. Bleed flow through Pilot Line.
- c. Flow Control Valve “open”.
- d. Liquid flow into tank.

2. Tank Filled (full);

- a. Level Sensor float valve “closed”.
- b. **No** bleed flow through Pilot Line.
- c. Flow Control Valve “closed”.
- d. Valve terminates (closes) liquid flow into tank.

Figure 10 illustrates an example of a FillSafe Zero system incorporating a Valve & Receiver Assembly in conjunction with a Banlaw BVLS model "venting" Level Sensor. The tank is being **refilled** in this illustration;

- **Level Sensor;** Pilot Line passage open, and BVLS venting air from the tank to atmosphere.
- **Flow Control Valve;** open, allowing fuel to enter the tank.
- **Dry-break Diesel Refuelling Nozzle;** securely connected and in the **ON** (open) position.

Note:



A Banlaw "remote" **filtered** (3µm abs.) tank breather system (refer Figure 12) is recommended to effectively remove airborne contaminants from airflow **entering** the fuel tank via the BVLS model venting passage. The (filtration) micron rating should be $\leq 5\mu\text{m}$ (abs.), or otherwise in accordance with the diesel plant equipment OEM guidelines. Alternatively, a BLS series non-venting Level Sensor can be used in conjunction with a Banlaw BFV225 series "filtered" Tank Vent (refer example in Figure 13). Both the BRFB01A Breather and BFV225 Vents incorporate the same Banlaw 3µm (abs.) air filter kit (Banlaw Part No. BFV225-KIT).

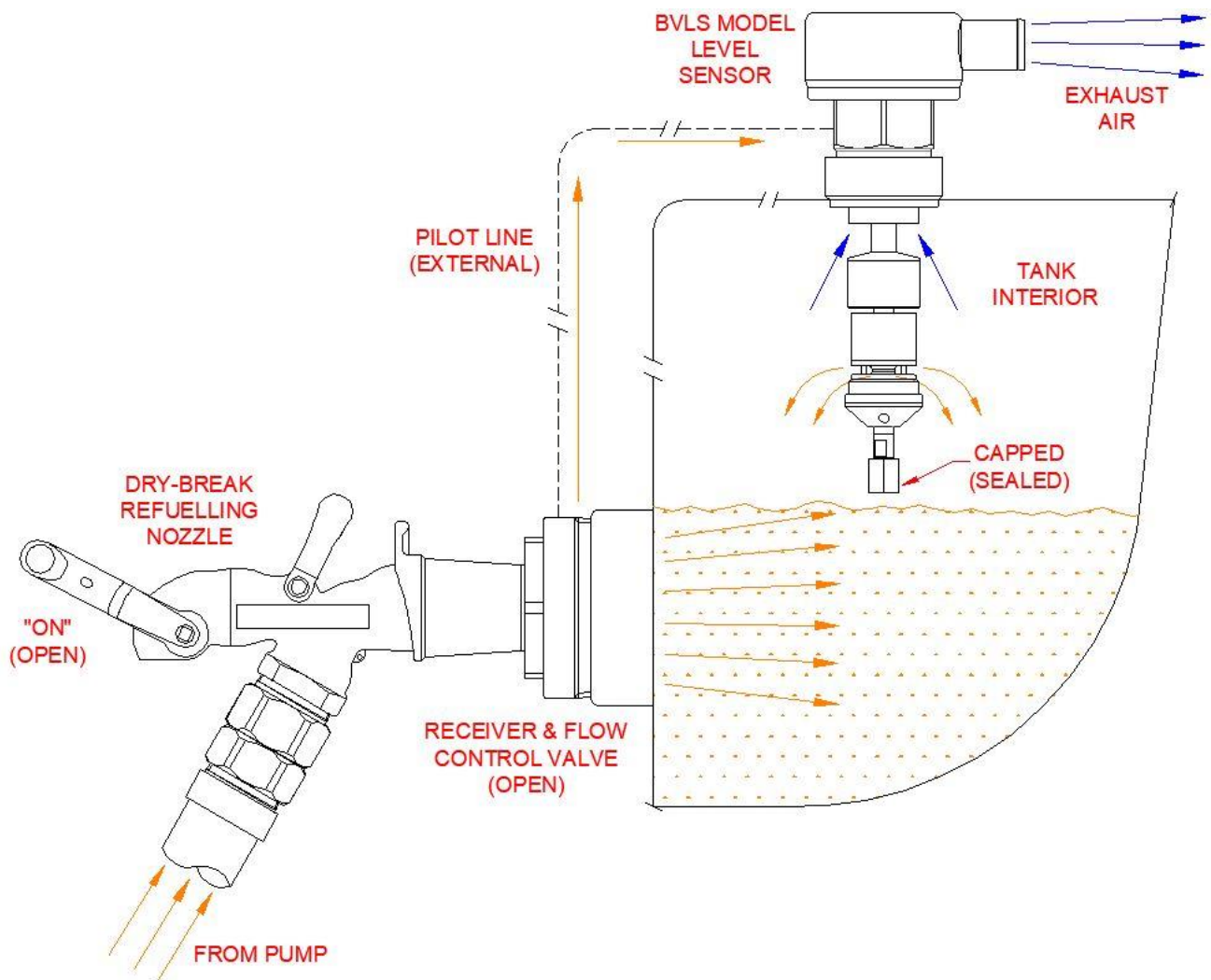

Figure 10 - Example of FillSafe Zero Installation - Tank Filling

Figure 11 now illustrates this same system once the tank has been filled to the nominated capacity;

- **Level Sensor;** Pilot Line passage closed.
- **Flow Control Valve;** closed, prohibiting fuel entering the tank.
- **Dry-break Diesel Refuelling Nozzle;** in the **OFF** (closed) position, awaiting disconnection.

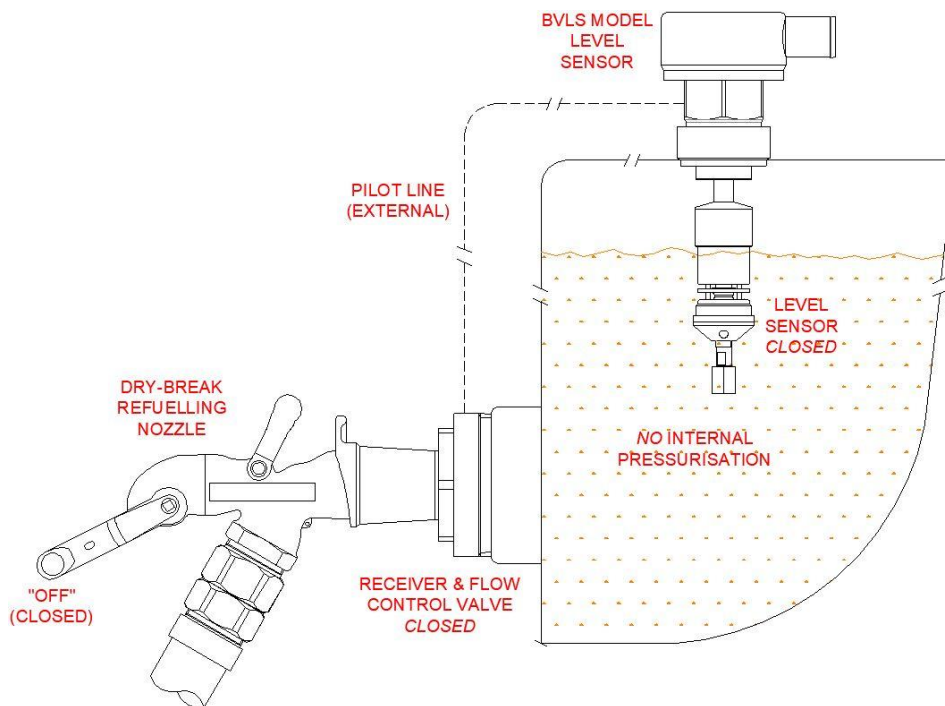

Figure 11 - Example of FillSafe Zero Installation - Tank Full

Note:



If filtration of air entering the tank is required with a Banlaw BVLS series venting Level Sensor, the intake/exhaust port of the Level Sensor may be connected to a remote filtered breather assembly such as the **Banlaw BRFB01A** – refer Figure 12.



Figure 12 - Banlaw BRFB01A "Remote" 3µm (abs.) Filtered Breather

Figure 13 illustrates a further example of a FillSafe Zero installation now with a Banlaw **non-venting** (BLS model) Level Sensor and a Banlaw tank vent (BFV225 model **filtered** vent shown). The operation of the FillSafe OFP system is the same as that illustrated in Figure 10 and Figure 11 incorporating the "venting" (BVLS model) Level Sensor assembly, with the exception that the function of tank venting (intake & exhaust) is now performed by the separate Vent assembly. The (patented) Banlaw BFV225 model Tank Vent incorporates a 3µm (abs.) air filtration for air **entering** the tank via the Vent.

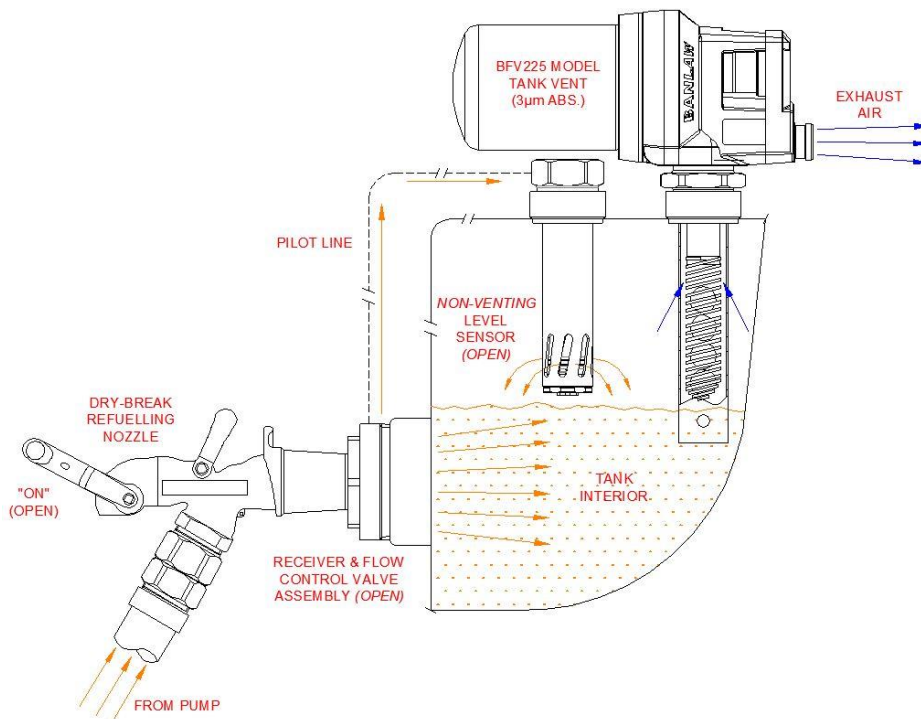

Figure 13 - Further Example of FillSafe Zero Installation - Non Venting Level Sensor

8 INSTALLATION & COMMISSIONING GUIDELINES

This Installation & Commissioning Guide is general, and is not meant to replace or override installation guidelines that arise out of a *due diligence* assessment of a Banlaw product for a specific (intended) application.

The scope of this section applies to the Flow Control Valve & Receiver assembly, e.g. BFCV23, etc. Whilst other FillSafe Zero products are mentioned – e.g. Level Sensors and Pilot Lines – end-users must refer to **separate** Banlaw documentation covering each product *prior* to installation.

Note:



General Installation Notes;

1. Conduct a **Job Hazard Analysis** (JHA) *prior* to install to mitigate health, environmental and equipment hazards.
2. Do **NOT** install any parts that are damaged or are otherwise faulty.
3. Do **NOT** install parts which are not compatible with mating parts or parts which do not satisfy the specifications of the FillSafe Zero system.
4. Conduct all necessary measures to **prevent the ingress of contamination** into the Banlaw Flow Control Valve and other parts.
5. Only engage threads of the **same thread type**. Ensure all threaded connections are clean and in good condition. Avoid over-tightening.
6. An appropriate thread sealant (eg Loctite 567) is recommended on the 4" NPT(M) process connection. Use thread sealant **sparingly** (avoid first 2-3 threads). Residual thread sealants etc. may cause contamination and malfunction of the FillSafe Zero system. No thread sealant is required on the JIC Pilot Line connection.
7. Use only proper **hand tools** for the installation of all components – e.g. Banlaw **BFCVSOCKET**. Avoid the use of power or impact tools, and adjustable wrenches (e.g. stilsons pipe wrench).
8. Use consumables (e.g. Loctite products) strictly in accordance with the OEM Safety Data Sheet (SDS) and operating guidelines. Do not use consumables beyond their expiry date.

8.1 Pre-Installation Guidelines

The maximum recommended angle (gradient) for the proper and reliable operation of the Flow Control Valve Assemblies is illustrated in Figure 14.

For any installations where these limits are likely to be exceeded contact Banlaw for assessment and advice.

This Valve may be installed directly onto the tank inlet port (4" NPT(F)) or "inline" within a piping system leading into the tank inlet. **All possible means shall be made to install the Valve as close to the tank inlet as practicable.**

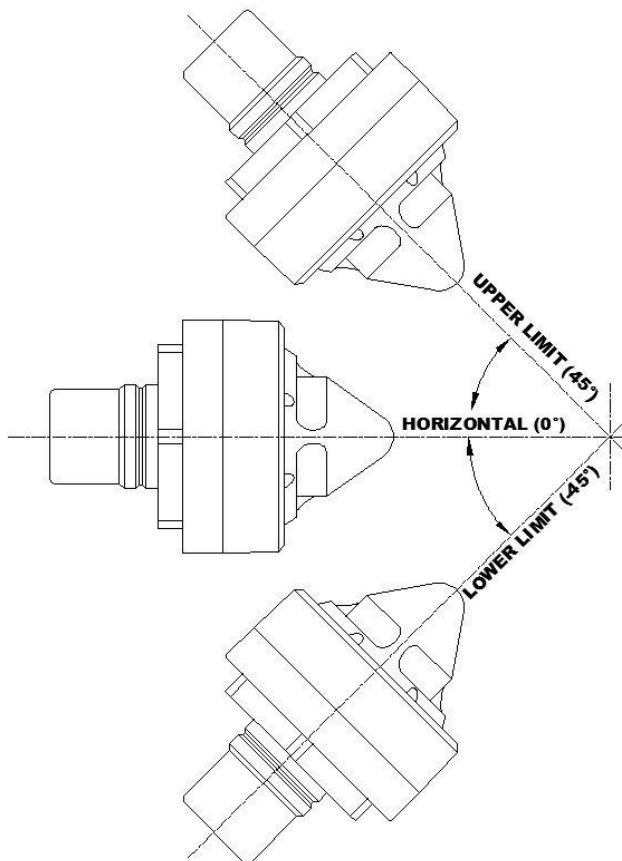

Figure 14 - Angular Limits of Valve Operation

The Valve outlet is a 4" NPT(M) threaded connection, requiring a mating **4" NPT(F) connection to the tank inlet**. The Valve may be installed directly to the tank inlet port or remote from the tank inlet – refer example in Figure 15. Banlaw can supply Adaptors to cater for a variety of Valve mounting requirements – please contact Banlaw for further information.

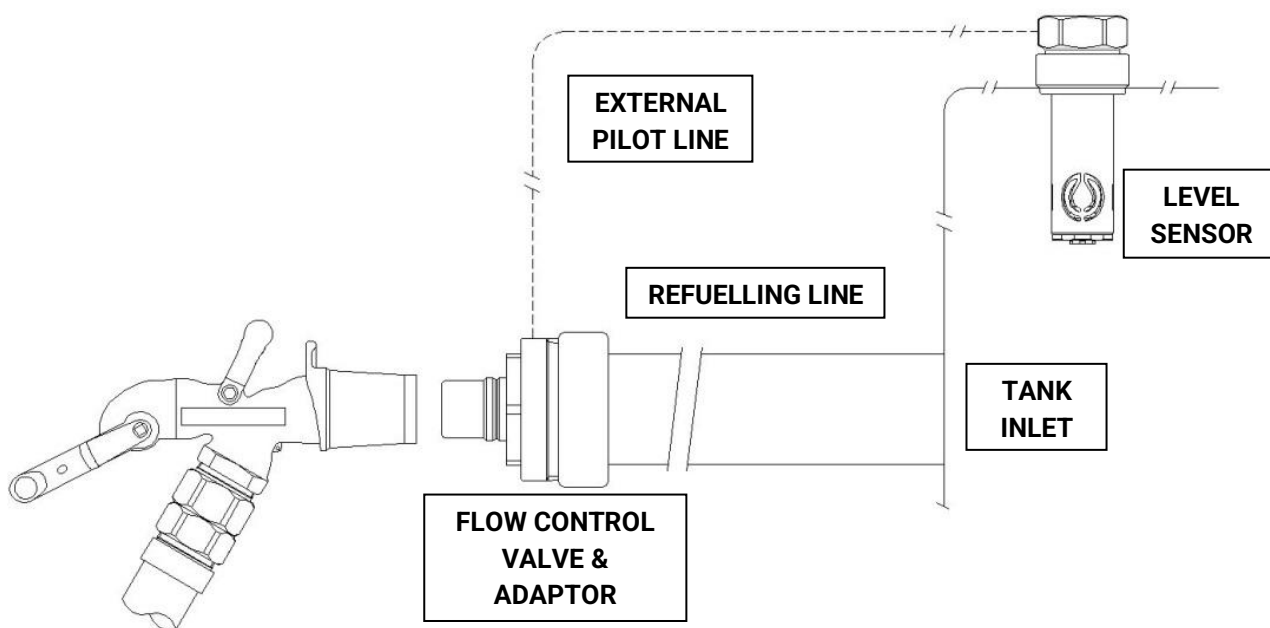

Figure 15 - Example of a Remotely Installed Valve

8.2 External Pilot Lines

Important limitations apply to the **Pilot Line** – please also refer to Banlaw document PRH-OPF-30 for further detail. Internal Pilot Lines are incompatible with this Valve.

Banlaw can provide an external pilot kit (Part No BFSZEPL-10M-KIT) which includes:

- 1 off 10m (33') length of DN12 hose.
- 2 off straight push on fittings.
- 1 off 90 degree swept elbow push on fitting.
- 2 off hose clamps.

External Pilot Lines used with this valve shall comply with the following key requirements;

1. Supplied by Banlaw, or otherwise manufactured strictly in accordance with Banlaw specifications.
2. Recommended hose specification;
 - i. AS/SAE 100 R1AT, or 100 R2AT.
 - ii. Rated to environmental and process temperature range.
3. Minimum ID (bore size) – 1/2" (DN12) up to a maximum length of 10m (33').
4. Maximum recommended vertical head; 4m (13') between Flow Control Valve location (lower) and Level Sensor location (top). Contact Banlaw for applications requiring an extended head height.
5. Hose tail couplings; 3/4" JIC(F) (or as per other Banlaw recommendation).
6. All fittings shall be an "open bore" and not a "reduced bore" style. Short (sharp) radius bends shall be avoided.
7. Minimum (internal) safe working pressure (SWP); 2,500kPa (25 bar, 363psi).
8. Installed external to the diesel tank;
 - i. To achieve the *minimum* possible Pilot Line length. Excess Pilot Line length should be avoided.
 - ii. Adequately supported using hose clamps (or similar) – refer Figure 16.
 - iii. Via a routing (pathway) which minimises the probability of damage due to sharp edges, impact, excessive wear & tear, and relative movement (e.g. rubbing) between the hose and another surface. Any potential contact with sharp edges or movement against a surface should be mitigated by improved routing or support of the hose, or by inclusion of a protective sheath (outer cover) over the hose.
 - iv. Any twisting or sharp (small) radius bends of the Pilot Line must be avoided.
 - v. Other than the weight of the Pilot Line itself, no additional mass or tension (stretch) shall be added to the hose assembly.
 - vi. Routing between 2 relative moving surfaces, e.g. through an articulated region of a vehicle (e.g. front-end loader, etc.), should be avoided where possible. If not, routing and support of the hose over this region must be as per the hose OEM guidelines for such applications to avoid accelerated wear and fatigue of the hose.

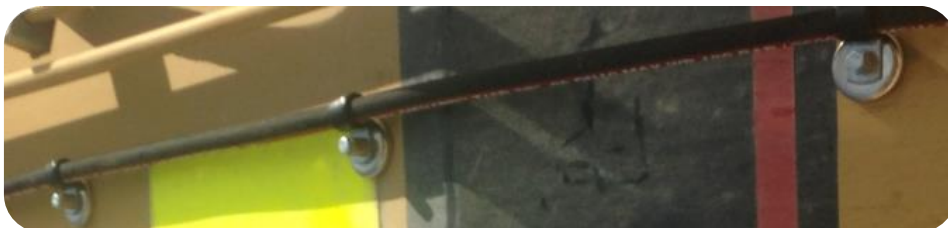

Figure 16 - Example of External Pilot Line Retention

9 INSTALLATION PROCEDURE



In preparation for the installation of this new FillSafe Zero Valve, **the fuel level within the tank must be below the tank fill point.** This will prevent the discharge (spillage) of fuel from the tank once the existing Valve, Receiver or other tank refuelling coupler is removed. If necessary, drain fuel from the tank into a clean reservoir for reuse, or otherwise dispose of in a responsible manner. The flow control valve (piston) within the valve is not designed nor intended to act as a non-return (check) valve.

1. Complete all necessary hazard mitigation, monitoring and control actions as per the JHA (or other local safe prework requirements).
2. Once the tank is ready (i.e. drained) to accept this new Flow Control Valve, remove the Valve from its packaging (leave within packaging until just prior to install). Remove any dust caps, plugs etc. from ports.
3. Check that the Valve piston is freely sliding within the Valve body, by gently rocking the Valve back & forth – the movement of the Piston is audible. The Piston should reciprocate under the effect of its own weight.
4. Inspect the 4" NPT(M) mounting thread for damage. Inspect the mating 4" NPT(F) thread for damage, and remove any contamination with a clean rag.
5. Inspect the external Pilot Line and Pilot Line connection for visual damage or defects. If condition is unsatisfactory, do **NOT** attempt to repair a damaged Pilot Line – instead replace with a new Pilot Line assembly constructed **in accordance with Banlaw specifications.**
6. Apply a suitable thread sealant (e.g. Loctite 567) to the 4" NPT(M) thread of the Valve. **Avoid the use of excessive Loctite.** Holding the Valve concentric with the mating adaptor, screw the Valve in by hand until hand-tight. Using a suitable hand tool – e.g. Banlaw BFCVSOCKET or 90mm deep socket, tighten the valve. There is no need to over or under tighten the valve as the pilot line port can be rotated to any position,
 - a. Do **NOT** use an impact (power) tool – use only hand tools.
 - b. Avoid over-tightening.
 - c. Avoid the use of a wrench on the front hex of the Valve – refer Figure 17.
 - d. A **thread-locking compound should not be necessary** on the 4" NPT(M) thread. Banlaw instead recommends a thread sealant with low to moderate thread-locking capability.



7. Take the Receiver Dust Cap lanyard and pass the pilot line through the "loop". Insert fitting into port on valve and tighten securely;
 - a. **Thread sealant is not required on the pilot line port.** Banlaw has provided a 3/4" JIC(M) – 1/4" UNO Nipple, which will seal the UNO thread to the Rotating Collar without the need for a thread sealing or locking compound. Ingress of a sealant into the Pilot Line fuel passage will contaminate the FillSafe Zero system and threaten its reliable operation.
 - b. Avoid over-tightening.
8. It is recommended a Commissioning Tag or Information Tag etc. is attached to the front of the Valve until such time as the proper functionality of the Valve and OFP system is confirmed during the Commissioning process – refer section 10.

10 COMMISSIONING PROCEDURE



Inspect the fuel tank(s) for signs of visible damage, distortion and fuel leakage which may indicate the past over-pressurisation of the tank(s) due to a failure with the overfill protection system previously used. ***If the root cause of such failure has not been identified and may not be mitigated by the installation of this new Valve, commissioning of the new Valve shall not commence until all such failures are identified, mitigated, controlled and/or managed.***

1. **Pre-commissioning checks** for a dry-break diesel refuelling system comprising FillSafe Zero;
 - a. Ensure **all** dry-break nozzles to be used with the installed system are compatible with the Banlaw Receiver fitted to the FillSafe Zero Flow Control Valve.
 - b. Inspect the tank vent breather for excessive contamination ingress, which may restrict the free flow of exhaust air during tank refuelling. If a breather hose is installed, inspect the hose outlet for contamination build-up and the hose for damage, kinking and distortion which could also affect airflow. If a filtered breather system is used, inspect the serviceable filter element for condition and replace if necessary.
2. When this FillSafe Zero Valve assembly is completely installed, and all other refuelling system components are all properly installed and awaiting commissioning, the initial (maiden) tank refuelling event shall serve as the means of commissioning the FillSafe Zero system.
3. **Prior** to any attempt to refuel the tank, ensure the fuel level is below the safe fill level (SFL) and subsequently, the OFP system will permit fuel to enter the tank for a period of no less than approx. 30secs (i.e. adequate time for system commissioning).
4. For **FuelTrack "Auto ID" Valves**, (only) e.g. BFTFCV23 and BFTFCV43;
 - a. Ensure the unique receiver serial tag ID (code) is loaded into the onsite FMS database and assigned to the applicable plant equipment (tank) asset number.
 - b. Once the mating Banlaw FuelTrack™ "auto ID" dry-break nozzle is connected, verify the local FMS depot (controller) reads (receives) the unique serial tag ID by referring to the depot screen.
5. Remove the Receiver Dust Cap from the Receiver and securely connect a Banlaw (or other compatible) dry-break refuelling Nozzle to the Receiver. Now disconnect and reconnect the nozzle to confirm ease of engagement with the receiver. In the event of a problem connecting or disconnecting the nozzle, please refer to the Troubleshooting Guide. Prepare to refuel the tank as per **normal refuelling procedure**.
6. Any air entrained within the FillSafe Zero system will need to be bled from the system until the system is fully operable. This is best achieved by throttling (reducing) the maximum achievable refuelling flowrate to approx. 50% and steadily oscillating the flowrate between zero and 50% - this can be readily achieved by manually cycling the operating (open/closed) handle of the refuelling nozzle, or similar means. Continue this for approx. 10-15sec.
7. Once the system is completely bled, the nozzle can be fully opened. If the nozzle automatically closes **prior** to the tank reaching capacity and the FillSafe Zero system closing, refer to Troubleshooting section. Do **NOT** manually or otherwise forcibly maintain

- the nozzle operating handle in the ON (open) position. Automatic shut-off of a Banlaw nozzle prior to the FillSafe Zero system closing is an issue known as premature nozzle shut-off, and should **not** be accepted as part of the refuelling process – contact Banlaw for further guidance.
8. Whilst the tank is being refilled, carefully check the FillSafe Zero system for any signs of fuel leakage. Mark/record any sources of leakage for prompt corrective action after the tank is refilled. If the degree of leakage is unacceptable, manually close the refuelling nozzle, disconnect it from the receiver and rectify the leak. If the fuel leakage occurs from between the nozzle and receiver, please refer to troubleshooting section.
 9. As the tank level approaches the nominated capacity (or SFL), remain next to the refuelling nozzle. If possible (and safe), ***closely monitor the fuel level to ascertain whether the FillSafe Zero OFP system automatically terminates the inflow of fuel into the tank at the required level without (internal) tank pressurisation.*** In the event of a failure, ***promptly*** close the refuelling nozzle or otherwise stop the fuel supply before the tank(s) is overfilled – refer Troubleshooting Guide. ***Only for this commissioning procedure***, manually reopen the Banlaw nozzle and hold it fully open for approx. 5sec. Confirm negligible (no greater than approx. 10LPM/4GPM) fuel can enter the tank by observing the flow meter measuring fuel dispensed via the nozzle. If additional fuel enters the tank, please refer to troubleshooting section.
 10. At the completion of refuelling, remove the Nozzle from the Receiver and return the Nozzle to its nominated holster or storage location. **Replace the Receiver Dust Cap on the Valve.**
 11. After the above commissioning procedure has been successfully completed, the FillSafe Zero system may be placed into service. A system that does not perform correctly should not be placed into service, but instead quarantined until the problem is identified and rectified.



In the event the root cause(s) of the OFP system failure cannot be identified and rectified prior to the next refuelling event, ***alternate means shall remain in place to prevent overfilling and over pressurisation of the tank*** until such root cause(s) are identified, mitigated, controlled and/or managed.



It is typically a legal responsibility of the person(s) who has identified the potential hazard to promptly report the event and if possible and safe, isolate the part of the system whose continued use may result in an unacceptable risk to health, safety and environment. Complete the applicable procedure for the proper and positive isolation of the system and promptly inform worksite management.

“ Undertake your Duty of Care ”

Banlaw FuelTrack™ “Auto ID” Flow Control Valves – e.g. BFTFCV23 and BFTFCV43 – incorporate a unique serial ID tag device, whose ID tag (code) is assigned to the tank or plant equipment (asset) onto which it is installed. Once the tag is assigned, the onsite Banlaw FuelTrack management system (FMS) automatically identifies the code and assigns any fuel dispensed into the tank/equipment to its asset number. FuelTrack incorporates a number of security features which include the prohibition of fuel dispensing into a tank/equipment which does not have a Banlaw BFT receiver fitted, or whose ID tag is not registered within the FMS database. It is therefore important that **the installation process of a BFT series flow control valve includes the entry of the unique receiver tag into the FMS database** – please liaise with your site FMS manager (e.g. fuel champion) for assistance. Figure 19 illustrates an example (only) of a BFT ID tag, also marked on the Receiver.



Figure 19 - Example of Banlaw FuelTrack™ Unique Receiver ID

11 REFUELLING OPERATION SEQUENCE

The FillSafe Zero system itself is fully “automated” and requires no manual operation or manipulation. The installation of the FillSafe Zero system onto a tank requires ***no change to the normal operating procedure of the dry-break refuelling system*** (i.e. the procedure by which a tank is normally refuelled).

Refuelling couplings (e.g. nozzle and receiver) that are contaminated with dust and other buildup ***must be cleaned prior to use***. This will help prevent;

- Contamination entering the FillSafe Zero system, subsequently increasing the probability of system failure.
- Contamination from entering the fuel stream, increasing the probability of engine fuel system problems.
- Accelerated wear & tear of mating parts.
- Damage to fluid seals, creating fuel leakage.
- Difficulty in properly engaging/connecting the nozzle and receiver.

The list illustrates a typical operating sequence for a dry-break system refuelling a tank fitted with FillSafe Zero. Equipment that is damaged, leaking or otherwise unfit for operation must not be used, but must instead be replaced or repaired prior to use of the system.

1**REMOVE RECEIVER DUST CAP. REMOVE NOZZLE FROM ANCHOR OR HOLSTER****2****RETRACT NOZZLE ACTUATOR AND PUSH ONTO RECEIVER. RELEASE ACTUATOR AND ALLOW IT TO RETURN FORWARD. PULL BACK SLIGHTLY ON NOZZLE TO CONFIRM SECURE CONNECTION WITH RECEIVER****3****START FUEL DISPENSING PUMP****4****MANUALLY OPEN REFUELLING NOZZLE. IF NOZZLE IMMEDIATELY SHUTS OFF, MANUALLY CYCLE NOZZLE BETWEEN OPEN AND CLOSED FOR APPROX. 2-3SECS. IF NOZZLE WILL STILL NOT REMAIN OPEN, CONFIRM TANK IS NOT ALREADY FILLED TO CAPACITY. IF NOT, REFER TROUBLESHOOTING GUIDE.****5****ALLOW TANK TO REFILL. IF REQUIRED BY SITE REFUELLING PROCEDURE, WITNESS ENTIRE REFUELLING EVENT WHILST VISUALLY MONITORING RISING FUEL LEVEL****6****ONCE TANK REACHES CAPACITY, THE FILLSAFE ZERO LEVEL SENSOR WILL “CLOSE”, PROMPTING THE FLOW CONTROL VALVE TO CLOSE. THE BANLAW NOZZLE WILL THEN PROMPTLY CLOSE. ENSURE NOZZLE OPERATING T-HANDLE IS SECURELY LATCHED IN “OFF” (CLOSED) POSITION PRIOR TO DISCONNECTION****7****STOP FUEL DISPENSING PUMP. RETRACT NOZZLE ACTUATOR AND DISCONNECT FROM RECEIVER. REPLACE RECEIVER DUST CAP AND RETURN NOZZLE TO STORAGE HOLSTER/ANCHOR**

Refer to supporting documentation such as the Banlaw Product Data Sheet (PDS) for the appropriate (installed) Banlaw FillSafe™ Zero Level Sensor for further information on such products and the FillSafe Xero system.

12 MAINTENANCE & SPARE PARTS

Replacement Receiver (i.e. front end) Kits and Receiver Dust Caps are available to suit each Valve assembly (refer Table 1). **No other aspect of the Valve is serviceable.**

Banlaw product warranty is void in the event;

- Non-genuine spare parts are used for product repair/servicing.
- Repairs are carried out by unauthorised personnel.
- Any attempt is made to repair/service a product deemed as non-serviceable by Banlaw.
- Products are subjected to abuse, tampering, neglect, or improper operation and maintenance.
- As per the terms and conditions of Banlaw product warranty - refer to Product Warranty section.

The following genuine Banlaw spare parts are available to suit Flow Control Valves.

BANLAW RECEIVER DUST CAPS

DESCRIPTION	PART No.
Dust Cap to Suit All "23" Series Flow Control Valves	AUS23C
Dust Cap to Suit "43" Series Flow Control Valves	AUS43C
Dust Cap to Suit "43" Cold Temperature Series Flow Control Valves	AUS43C-CT

BANLAW FLOW CONTROL VALVE – DRY-BREAK RECEIVER KITS

DESCRIPTION	PART No.
Fuel Receiver Kit to Suit BFCV23 Flow Control Valve	BFCV23-KIT
Fuel Receiver Kit to Suit BFCV23-CT Cold Temperature Flow Control Valve	BFCV23-CT-KIT
Fuel Receiver Kit to Suit BFCV23R Flow Control Valve	BFCV23R-KIT
Fuel Receiver Kit to Suit BFCV23R-CT Cold Temperature Flow Control Valve	BFCV23R-CT-KIT
Fuel Receiver Kit to Suit BFCV43 Flow Control Valve	BFCV43-KIT
Fuel Receiver Kit to Suit BFCV43-CT Cold Temperature Flow Control Valve	BFCV43-CT-KIT
Fuel Receiver Kit to Suit BFTFCV23 Flow Control Valve	BFTFCV23-KIT
Fuel Receiver Kit to Suit BFTFCV23-CT Cold Temperature Flow Control Valve	BFTFCV23-CT-KIT
Fuel Receiver Kit to Suit BFTFCV23R Flow Control Valve	BFTFCV23R-KIT
Fuel Receiver Kit to Suit BFTFCV23R-CT Cold Temperature Flow Control Valve	BFTFCV23R-CT-KIT
Fuel Receiver Kit to Suit BFTFCV43 Flow Control Valve	BFTFCV43-KIT
Fuel Receiver Kit to Suit BFTFCV43-CT Cold Temperature Flow Control Valve	BFTFCV43-CT-KIT

Table 1 - Genuine Banlaw Spare Parts



Figure 20 - Examples of Banlaw Receiver Kits (BFCV23R-KIT on left, BFCV43-KIT on right)

13 PREVENTATIVE MAINTENANCE

The integrity (sound working condition) of refuelling couplings and tank overflow protection systems is critical to ensure all equipment can be operated in a safe and proper manner.

The working life of equipment depends on many factors, particularly the environment in which it operates and the care and manner by which equipment is treated and maintained. Dusty and dirty environments more prone to contamination buildup in equipment such as refuelling couplings cause accelerated wear & tear, as does excessive contamination within the fuel stream. Due to the many varied operating environments in which Banlaw equipment is used, any preventative maintenance information provided within this document shall be used a guide – unless noted otherwise.

The FillSafe Zero system contains relative moving parts and fluid seals which will wear after a period of use. **Such wear will be accelerated by contamination within refuelling couplings and within the fuel stream itself.** Excessive contamination within the fuel stream may even cause malfunction of the dry-break refuelling equipment and FillSafe Zero system;

- *Excessive* fuel contamination levels could best be expressed as automotive grade diesel fuel containing contamination levels beyond those stipulated by governances and guidelines such as; the Australia Fuel Standard (Automotive Diesel) Determination, the current Worldwide Fuel Charter (WWFC), and fuel quality requirements of modern diesel engine (or plant equipment) manufacturers.

The following preventative maintenance guidelines apply to the Banlaw Flow Control Valves;

1. Ensure adequate controls and condition monitoring are in place to ensure the contamination levels (and other specifications) of your fuel supply are maintained – **PREVENT** poor quality fuel entering your sites fuel infrastructure and plant equipment.
2. As required, install inline (bulk) filtration on all diesel dispensing lines – contact Banlaw for advice.
3. Conduct routine fuel sampling to monitor fuel quality and contamination levels.
4. Maintain the use of the Receiver Dust Cap and Nozzle Anchors, Holsters, or Dust Caps.
5. Remove any contamination from the dry-break Receiver (front end) **prior** to connecting a Nozzle.
6. Visually inspect the Receiver for excessive wear & tear or damage **prior** to connecting a Nozzle.
7. Install a new (genuine Banlaw) front end Receiver Kit;
 - a. When the Receiver is excessively damaged – refer examples in Figure 21 and Figure 22.
 - b. When fuel leakage occurs from the front (Poppet seal) of the Receiver.
 - c. Otherwise, no later than every 3 years (mining) and 5 years (rail).
8. Routinely inspect the FillSafe Zero Pilot Line for damage, leaks, kinks, etc. Repair/replace as necessary. It is recommended the External Pilot Line is replaced no later than every 5 years.
9. Replace the Valve assembly no later than every 8 years.



Figure 21 – Excessive Wear to Ball Lock Annulus

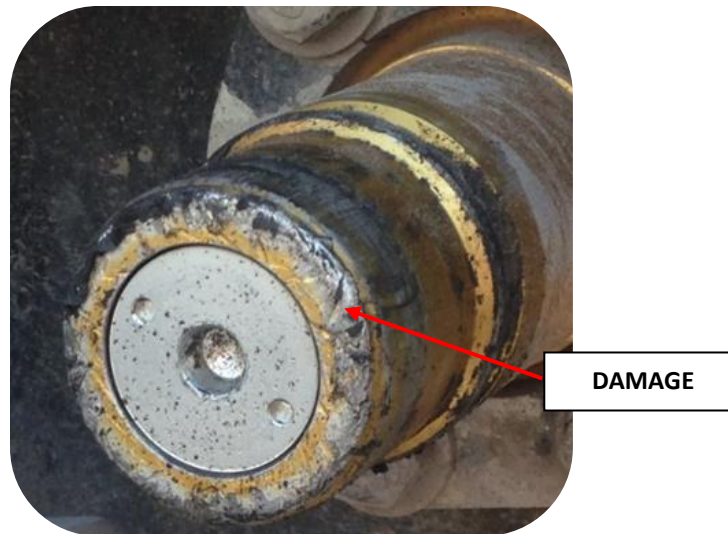

Figure 22 - Wear to Front of a non-Banlaw Aluminium Receiver

Please contact Banlaw or your nearest Banlaw agent for more detailed preventative maintenance information on a specific product application.

13.1 Banlaw Site Service and Preventative Maintenance

Clients can benefit from a **Banlaw Service Level Agreement (SLA)** to assist in the preventative and corrective maintenance of a FillSafe Zero system onsite, in addition to other diesel, fuels, oils and coolant infrastructure. Clients with an SLA can **focus on their core business activities** and allow experienced Banlaw technicians and engineers to help keep such infrastructure operating at optimum **safety, performance and reliability**. Contact Banlaw for further information.

14 TROUBLESHOOTING

This section provides troubleshooting recommendations for this Flow Control Valve and the FillSafe Zero system when installed, operated and maintained in accordance with Banlaw guidelines.

PROBLEM	PROBABLE CAUSE AND SOLUTION
<p>Premature nozzle shut-off at the <i>start of or during</i> refuelling.</p>	<ul style="list-style-type: none"> • Zero system requires bleeding (to remove air). With the supply pump running, cycle nozzle T-handle between ON and OFF several times to resolve this issue (also refer section 10). • Residual pressure in Pilot line. Cycle nozzle T-handle between ON and OFF several times to resolve this issue. • Pilot line blocked/obstructed, kinked or undersized. Check Pilot line size and connections for blockages or obstructions. Avoid the use of restricted bore style fittings, sharp elbows etc. within the Pilot Line routing between the Flow Control Valve and Level Sensor. • Level Sensor installed too high (over 4m (13')) above the Flow Control Valve). • The BVLS model "venting" Level Sensor is not installed correctly onto the tank, e.g. installed within an "extended" socket or riser pipe etc. Refer to BVLS requirements (i.e. PDS document) and rectify. • Float Valve at base of Level Sensor is "stuck" in the closed (up) position. Remove Level Sensor, investigate, identify root cause and rectify. • Faulty Level Sensor. Replace Level Sensor. • Piston mechanism within Flow Control Valve is "stuck" in the closed (forward) position or otherwise restricted in its "free" reciprocating action. Remove Valve, investigate, identify root cause and rectify. • Faulty Flow Control Valve. Replace Flow Control Valve. • Flow rate below recommended minimum. Increase delivery flow rate. • Flow rate above recommended maximum. Reduce delivery flow rate. • Faulty nozzle. Replace nozzle. • Excessive restriction to the "free" discharge of air from the tank's venting (breather). Check vent(s), vent exhaust, breather hose, and filtered breather system (if fitted) for the source of the restriction. Also confirm the venting system is rated for the tank refuelling flowrate. • Excessive restriction in the refuelling line connecting the Receiver to the Flow Control Valve. Upsize line size (bore) and remove short radius bends and unnecessary chokes to fuel flow. • Accidental/premature activation (closure) of the Level Sensor by fuel movement (sloshing) in the tank. Pause for 1 min and restart refuelling.

PROBLEM	PROBABLE CAUSE AND SOLUTION
Nozzle shut-off and/or Flow Control Valve closure as tank approaches SFL (capacity).	<ul style="list-style-type: none"> • Accidental (premature) trigger of the Level Sensor by fuel movement in the tank. Pause for 1 min (60 seconds) to allow fuel to settle and try again. • Incorrect Level Sensor for the required ullage. Contact Banlaw or your nearest Banlaw agent for advice.
Fuel discharged from vent outlet during refuelling	<ul style="list-style-type: none"> • The fuel discharge stream (flow) into the tank is impacting the tank venting passage. Refer to the Level Sensor PDS for guidance. • Pilot Line fuel flow discharged from Level Sensor into tank is impacting the tank venting passage. Refer to the Level Sensor PDS for guidance.
Tank overfilling	<ul style="list-style-type: none"> • Incorrect Level Sensor for the required ullage. Contact Banlaw or your nearest Banlaw agent for advice. • Leakage through Pilot line and/or connections. Check Pilot line and connections. • Float Valve within Level Sensor has failed to close. Remove Level Sensor, investigate, identify root cause and rectify. • Faulty Level Sensor. Replace Level Sensor. • Piston mechanism within Flow Control Valve is "stuck" in the open (rearward) or otherwise restricted in its "free" reciprocating action. Remove Valve, investigate, identify root cause and rectify. • Faulty Flow Control Valve. Replace Flow Control Valve. • Flow rate below the recommended minimum. Maintain flowrate within the recommended minimum and maximum range.
Fluid Leakage between Nozzle and Receiver during Refuelling	<ul style="list-style-type: none"> • Worn Receiver and/or Nozzle preventing effective locking of Nozzle to Receiver. Install new Receiver Kit or replace and/or Nozzle. • Dirt and debris interfering with locking action and/or fluid seals. Clean both Nozzle and Receiver and ensure that the Receiver Dust Cap and Nozzle Holster (or Plug) are always used. • Front face of Receiver is damaged. Install new Receiver Kit. • Seals worn out on Nozzle. Replace Nozzle and return to Banlaw repair agent for servicing.
Fluid Leakage From Flow Control Valve – around Receiver	<ul style="list-style-type: none"> • Damaged O'Ring between Receiver and adjacent Flow Control Valve Body. Install new Front End Receiver Kit.
Fluid Leakage From end of Receiver	<ul style="list-style-type: none"> • Worn Poppet Seal in Receiver or debris on Seal. Remove Receiver sub-assembly and inspect seal. If damaged, install new Front End Receiver Kit.
Nozzle Uncouples During Refuelling	<ul style="list-style-type: none"> • Incorrect combination of Nozzle and Receiver. Confirm compatibility. Only use the correct combination of Nozzle and Receiver. • Worn ball lock mechanism on Nozzle and/or Receiver. Inspect both equipment and replace if necessary. • Contamination within ball lock groove on receiver body. Clean thoroughly and reconnect nozzle. • Nozzle improperly coupled to Receiver. Try again.
Fuel drains from	<ul style="list-style-type: none"> • The Piston within the Flow Control Valve is not designed nor

PROBLEM	PROBABLE CAUSE AND SOLUTION
Tank via the Flow Control Valve	intended to act as a normally closed check (one way) valve. Fuel must be drained within the tank to a level below the Valve prior to installing or removing the Valve or a Receiver Front End Kit
No fuel issued via Nozzle	<ul style="list-style-type: none"> • Banlaw FuelTrack™ Receiver ID tag (code) has not been entered into the onsite FMS database and/or properly configured within the database. • FuelTrack receiver ID tag has not been received by local FMS depot; <ul style="list-style-type: none"> a. Existing fault with auto ID dry-break system – investigate and rectify. b. Faulty auto ID chip in receiver – install new Banlaw receiver kit. c. Turn nozzle on (open) and verify code is read. d. Contact your onsite FMS “champion” or Banlaw Helpdesk. e. Battery failure on Wireless Swivel. • Non FuelTrack Nozzle installed in a ResTrack system. • Supply system issue due to pump failure, blocked flow meter etc.

15 PRODUCT RECYCLING & DISPOSAL

Banlaw values and supports the sustainable use of resources, and the safe, responsible and proper disposal or recycling of all materials within its products. For a description of the principal materials within the Banlaw FillSafe™ Zero system, please refer to the specification Table.

16 PRODUCT WARRANTY

Banlaw is committed to providing quality products and services. To provide further assurance, our products and services are backed by generous warranties.

A copy of the Banlaw product warranty terms and conditions is available from Banlaw, the Banlaw website, or your nearest authorised Banlaw agent.



www.banlaw.com