

Banlaw DEFMate Flush Face Fluid Coupling

Thank you for purchasing this high quality Banlaw product. Please read through and understand the information in this Product Data Sheet (PDS) **BEFORE** installation or operation of the product to avoid potential health safety and environment (HS&E) risks or property damage.

1 PRODUCT DESCRIPTION

The Banlaw DEFMate Flush Face fluid coupling is specially designed for the *clean, safe and efficient transfer of Diesel Exhaust Fluid (DEF) / AdBlue®* as commonly used in the mining, construction and transport industries. The coupling is completely manufactured from stainless steel to ensure chemical compatibility with DEF transfer.



Figure 1 – DEFMate Nozzle and Receiver

1.1 Diesel Exhaust Fluid (DEF) Definition

Diesel Exhaust Fluid (DEF) / AdBlue® is a solution of 32.5% urea and 67.5% deionized water. DEF is injected into the exhaust system of diesel-powered vehicles to turn harmful nitrous oxide (NOx) gases into nitrogen and water. This system is called a Selective Catalytic Reduction (SCR) which has been implemented to meet emission reduction targets.

2 IMPORTANT RESTRICTIONS ON THE USE OF THIS PRODUCT



1. The safe installation and subsequent operation of a Banlaw product relies on the completion of all necessary *“due diligences”* specifically for the assessment of the Banlaw product(s) being suitable for the intended application(s). Such an assessment is best achieved through the cooperation of the supplier/OEM (Banlaw) and the customer or end-user. Once such an assessment deems the Banlaw product(s) to be suitable, the customer or end-user shall ensure effective *“change management”* applies should any prominent or influential aspect of the application (upon which the initial assessment was based) be subject to change and may affect the ongoing suitability (i.e. safety and proper function) of the Banlaw product.



1. In accordance with the EU Pressure Equipment Directive (PED 97/23/EC), no Banlaw LubeCentral product is to be used with a Group 1 (dangerous) substance within the EU. (As per Banlaw’s internal assessment of the PED during October 2010). Unless noted otherwise by Banlaw, the Banlaw LubeCentral™ DEF Couplers have *not* been assessed under any other Regulatory or Industry Standard, Code, Directive, Guideline or other governance which may apply to the use of this product in specific applications. Please consult Banlaw prior to installation if in doubt.
2. To avoid potentially serious safety hazards, no attempt should be made to *connect* or *disconnect* the couplings during fluid flow or whilst the fluid within the couplings remains pressurised#. A maximum# of 50kPa(g) (7.3psig) residual pressure is the recommended limit.
3. The Banlaw LubeCentral™ DEF Couplers are designed solely for use with Diesel Exhaust Fluid (DEF) / AdBlue® found in the mining, construction, rail and similar industries. **Please contact Banlaw *prior* to the use of this product with other (foreign) liquids.**

Note:



1. This product is unsuitable for use with an alternative fluid (or substance) whose properties may affect the safety, function or reliability of the product. Please consult with Banlaw to confirm fluid compatibility if in doubt.
2. For DEFMate coupling **dimensions** and the **Part Numbers** of the various Couplers and accessories available, please refer to the relevant Banlaw Product Specification Guide (PSG), the Banlaw website, or contact Banlaw or your nearest Banlaw authorised distributor.

3 PRODUCT SPECIFICATIONS

Operating Temperature Range*	-10°C to 55°C (14 to 131°F)
Operating Temperature Range#	-40°C to 55°C (-40 to 131°F)
Maximum Operating Pressure (SWP) DEF Nozzle only	8,125 kPa (1,178 psi) The SWP must not be exceeded.
Maximum Operating Pressure (SWP) DEF coupling coupled	6,105 kPa (885 psi) The SWP must not be exceeded.
Maximum Fluid Flowrate	120 LPM (31.7 GPM)
Compatible Fluids (refer also Material Composition)	Diesel Exhaust Fluid (DEF) / AdBlue® 32.5 % urea / deionized water solution
Material Composition	Stainless steel, Viton (FKM) / HNBR
Process Connections	Nozzle – 1" NPT female Receiver – 3/4" NPT male Receiver – 1-5/8" -12 UN male / 1-5/16" -12 UN female
DEF Receiver Heater Port	1/2" BSPP female

* DEF receiver fitted WITHOUT optional DEF Heater - DEF / AdBlue® has a freezing point temperature of -11°C (12°F)

DEF receiver fitted WITH optional DEF Heater – refer section 6

Table 1 - Operating Specifications

Legend: “SWP”; Maximum recommended Safe Working Pressure (do not exceed).

“Coupled”; DEF Nozzle and DEF Receiver fully connected (engaged)

- Notes:**
1. All pressure data refers to the **internal** fluid pressure within the coupling(s), where each coupling(s) is in “as new” condition.
 2. Mating couplings should be depressurised prior to connection or disconnection.
 3. “Receiver”; male coupling, typically used on the “reservoir” (recipient) side of the fluid transfer system.
 4. The SWP of the DEF Receiver corresponds to the “**Coupled**” SWP in the table above.
 5. “Nozzle”; female coupler, typically used on fluid supply (dispensing) side.
 6. Operating Pressures tested at approx. 25°C (77°F) ambient temperature.
 7. All data refers to Couplers in an undamaged “as new” condition and is subject to a tolerance (variation) due to inherent, expected changes in the mechanical properties of materials of construction because of such factors as; raw material specifications, temperature, aging, fatigue, mechanical wear, etc.

Please contact Banlaw should you require additional technical information.

Table 2 below states the complete range of DEFMate products that are available for purchase from Banlaw.

Part Number	Type	Description
BDEFN25N	Flush Face Nozzle	Nozzle, DEF, 1" NPT(F) - Incl. Cap
BDEFR19N	Flush Face Receiver	Receiver, DEF, 3/4" NPT(M), c/w BSPP Plug - Incl. Cap
BDEFR41UNF	Flush Face Receiver	Receiver, DEF, 1-5/8" -12 UN(M), c/w BSPP Plug - Incl. Cap
BDEFHD	DEF Heater / Spare Part	Heater, DEF, 24V, 1/2" BSPP(M), 254mm LG, Deutsch
BDGNC	Spare Parts	Refer to Section 7.1 for details of available Spare Parts
BDEFRCC		
BDEFA001 BDEFA002A BDEFA003A BDEFA004 BDEFA005 BDEFA006 BDEFA007 BDEFA008 BDEFA009 BDEFHA001	DEF Adaptors	Refer to Section 6.7 for details of available DEF system Adaptors

Table 2 – Available DEFMate Products

4 KEY FEATURES

The Banlaw DEFMate Couplers incorporate the following key features;

- **“Dry-Break”** (normally closed) function.
- **“Push to Connect”** operation, i.e. the Nozzle actuator (collar/sleeve) does not need to be manually retracted to engage the Nozzle with a mating Receiver – the Couplers are simply “pushed together”.
- **“Flush-Face”** design, markedly reducing the opportunity for contamination ingress and build-up into the Couplers and the fluid stream. Residual contamination can be cleared using a clean rag.
- **“Ball Lock Latching Mechanism”**; typically considered the most secure means of fluid coupler mechanical “latching” (connection).
- **“Chemical Compatibility”**; metallic components manufactured from stainless steel materials to suit the harsh, corrosive nature of Diesel Exhaust Fluid (DEF) / AdBlue®.
- **“DEF Coupler Dust Caps”**; each DEF Receiver and DEF Nozzle is supplied with a stainless steel Dust Cap to minimise contamination build-up (crystallisation) on the Receiver and Nozzle when not in use.

5 INSTALLATION GUIDELINES

5.1 Pre-Installation Guidelines



- Any proposed installation/application/operation of the Banlaw DEF Couplers shall satisfy the Specifications detailed in section 3, and other requirements within this document. As fluid transfer is typically conducted at relatively high pressures, the specifications for any *other* parts, equipment and accessories used with these Couplers must also comply with the parameters (e.g. pressure, temperature, flowrate, etc.) of the application. ***Failure to ensure the DEF Couplers and other equipment are used strictly in accordance with their applicable specifications will introduce potentially serious safety hazards.***
- This Product shall only be used by **competent persons**, trained and/or directly supervised in their safe and proper operation.
- **A safe means shall be provided to bleed residual fluid pressure from within the Couplings (Nozzle and Receiver) prior to connection and disconnection.**
- The manual effort required to connect and disconnect these DEF Couplers has been minimised as far as is practicable, however the operation of the Couplers must consider **ergonomics** to avoid potentially serious work health & safety (WHS) hazards. I.e. the way in which the Couplers are used for **each** intended application must be part of a pre-installation due diligence assessment. Difficulty in the manual handling of the couplers and the remaining fluid transfer system equipment may not only introduce such WHS hazards, but also foster negligence to perform the required fluid transfer operation. Key manual handling tasks are likely to include;
 - Operation of a manual valve(s) – if fitted.
 - Carriage of the fluid dispensing hose and dispensing equipment to & from the storage location and the fluid service point (i.e. DEF Receiver location).
 - Connection of the Couplers, particularly at extended reach.
 - Disconnection of the Couplers, particularly at extended reach.
- Fluids used with these Couplers must be rated and otherwise suitable for the requirements of the application, particularly temperature. The use of these Couplers with a fluid at a temperature near or below its Pour Point may increase the risk of Coupling malfunction and difficulty of operation.

The use of an isolation valve (e.g. manual ball valve) upstream to *the DEF Nozzle inlet* is recommended to provide a means of isolating supply (pump) pressure from the Nozzle prior to disconnection from the receiver. Fluid pressure within both couplers must be bled prior to connection.

Figure 2 below is an example of a Diesel Exhaust Fluid (DEF) transfer system incorporating the Banlaw DEF coupling. Receivers can be installed using a 54mm (2-1/8") deep (e.g. hub) socket.

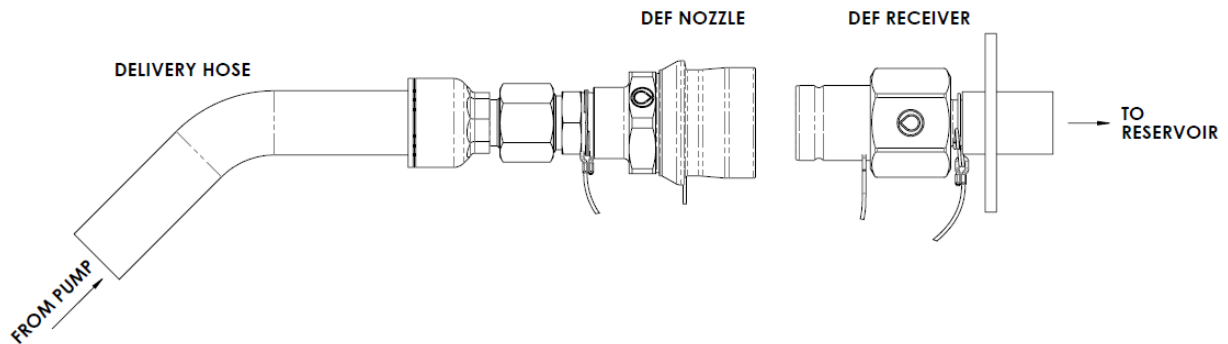

Figure 2 - Example of a fluid transfer system using the DEF Coupling



To improve ease of use (ergonomics) in the event the DEF Receiver is installed at a height above (human) chest height (i.e. approx. 1.2m, 4'), end-users may benefit from the installation of an *elbow* (e.g. 30°, 45° or 90°) between the Receiver outlet and its process connection – refer example in Figure 3.

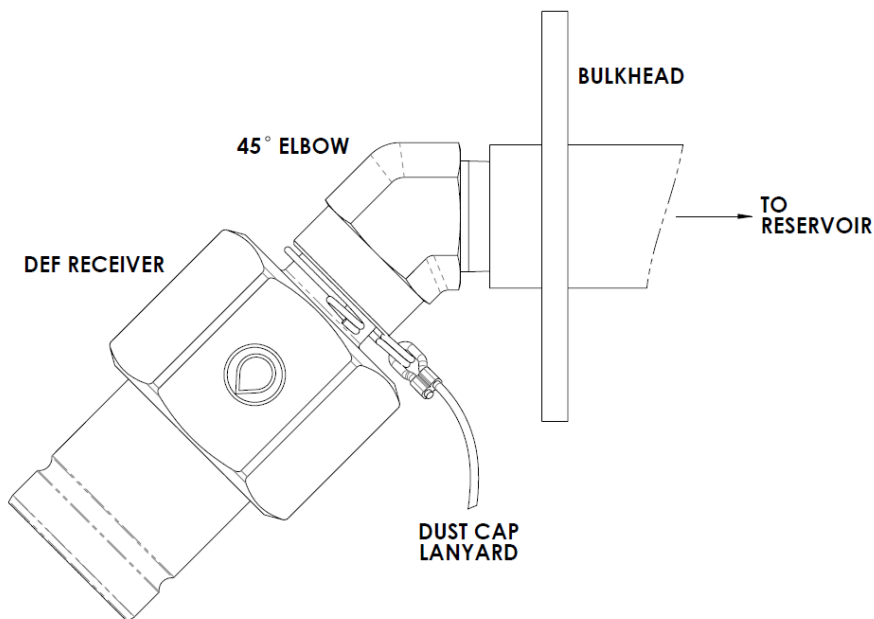

Figure 3 - Example of a DEF Receiver fitted with an Elbow

5.2 Installation Guidelines

Note:



General Installation Notes;

1. Conduct a **Job Hazard Analysis (JHA)** prior to install to mitigate health, environmental and equipment hazards. Use appropriate PPE.
2. Do **NOT** install any parts that are damaged or are otherwise faulty.
3. Do **NOT** install parts which are not compatible with mating parts.
4. Conduct all necessary measures to **prevent the ingress of contamination** into the DEF couplers and other parts.
5. Only engage threads of the same thread type. Ensure all threaded connections are clean and in good condition. Avoid over-tightening.
6. An appropriate thread sealant is recommended on NPT tapered threaded process connections. Use **sparingly** and avoid excess use of Loctite and similar products – *residual thread sealants etc. may cause contamination and malfunction of the Couplers.*
7. Use only proper **hand tools** for the installation of all components – e.g. 2-1/4” (57.15mm) spanner for DEF Nozzles and 54 mm deep socket (e.g. BPLRSOCKET) for DEF Receivers. Avoid the use of power or impact tools, and adjustable wrenches (e.g. stilsons).
8. Use consumables (e.g. Loctite products) strictly in accordance with the OEM Safety Data Sheet (SDS) and operating guidelines. Do not use consumables beyond their expiry date.
9. Ensure all likely **energy sources** – e.g. fluid pressure – are appropriately isolated and/or eliminated prior to installation of the DEF Couplers and other parts.
10. Ensure all **Dust Cap** lanyard “split rings” are secured to the threaded process (outlet) connection of each Coupler during installation, or otherwise secured to a location adjacent the Couplers.

6 BASIC OPERATING INSTRUCTIONS



- Do **NOT** attempt to either connect or disconnect the DEF Couplers whilst ever residual fluid pressure remains within a Coupling (Nozzle or Receiver);
- Do **NOT** attempt to connect (use) a DEF Coupling with any fluid except Diesel Exhaust Fluid (DEF) / AdBlue® or other fitting.
- Do **NOT** operate a DEF Coupler or any other fluid evacuation equipment that is damaged or otherwise faulty and potentially unsafe for use.
- Do **NOT** make any attempt to connect DEF Coupling without first removing contamination from the mating surfaces of each Coupler.
- Do **NOT** make any attempt to open a DEF Coupler by any means other than connecting with a mating DEF Coupler. For example, no attempt shall be made to bleed residual fluid pressure from a Coupler by manually opening a Coupler using a tool or foreign object or loosening the process connection to a Coupler – instead use a dedicated bleed valve.

How the DEF Coupling is connected (engaged) and disconnected (disengaged) is the same as other similar industry “**push to connect**” fluid couplings incorporating a ball-lock style latching mechanism – e.g. common fluid power (hydraulic) Couplers.

6.1 COUPLING CONNECTION

1. Unless specific site (application) liquid dispensing procedures dictate otherwise, ensure the liquid supply pump is **OFF** (i.e. not running) prior to Coupler connection.
2. Retrieve the DEF Nozzle and attached hose from their designated storage holster. Inspect all such equipment for signs of fluid leakage, damage or other defects. Safely **carry** the equipment over to the DEF Receiver, i.e. the fluid servicing point – do **NOT** drag the Nozzle along the ground.
3. Using the designated fluid pressure bleed procedure, bleed all measurable pressure from within the Couplings.

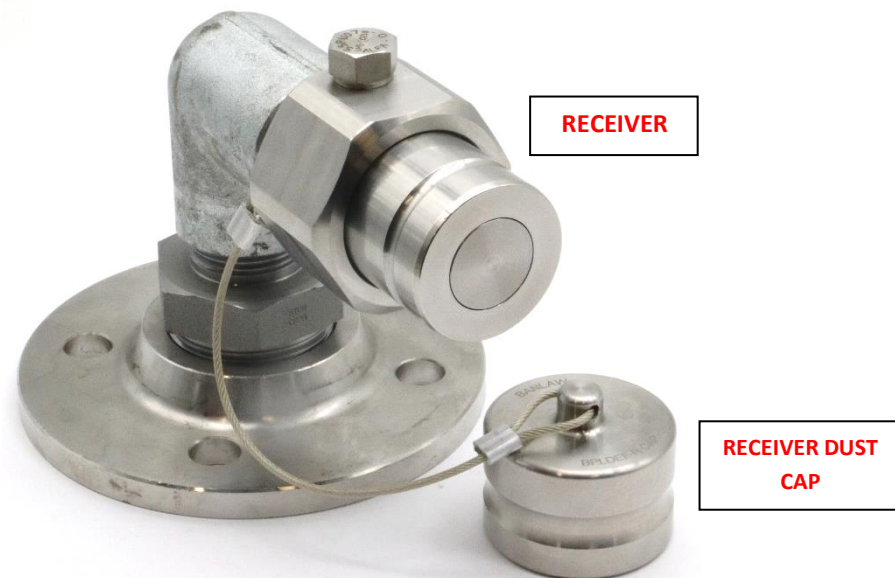

Figure 4 - Dust Cap Removed & Receiver Wiped Clean

4. If installed, ensure the manual valve adjacent the **Nozzle** inlet is in the ON (open) position. Closing the valve is likely to increase the manual effort required for connection due to hydraulic lock.
5. Verify the **Receiver** is bled to remove residual pressure.
6. Remove Dust Cap from Nozzle. Remove any residual contamination from the front face of the Nozzle using a clean rag.
7. Remove Dust Cap from Receiver. Remove any residual contamination from the Receiver using a clean rag.
8. Whilst supporting the weight of the Nozzle etc. concentrically **align** the Nozzle with the Receiver, “feeling” the front end of the Receiver fit within the shallow recess on the mating face of the Nozzle.

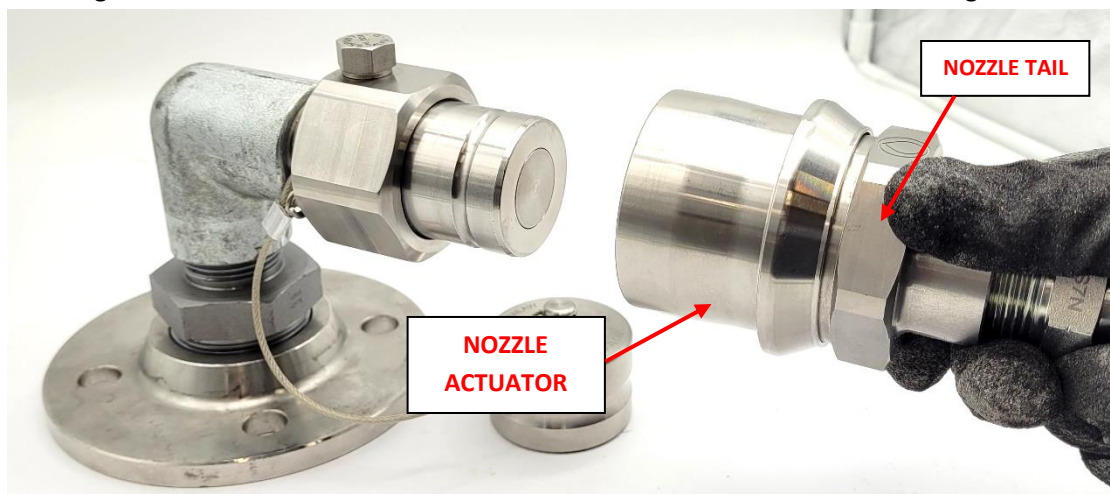

Figure 5 - Aligning Nozzle with Receiver

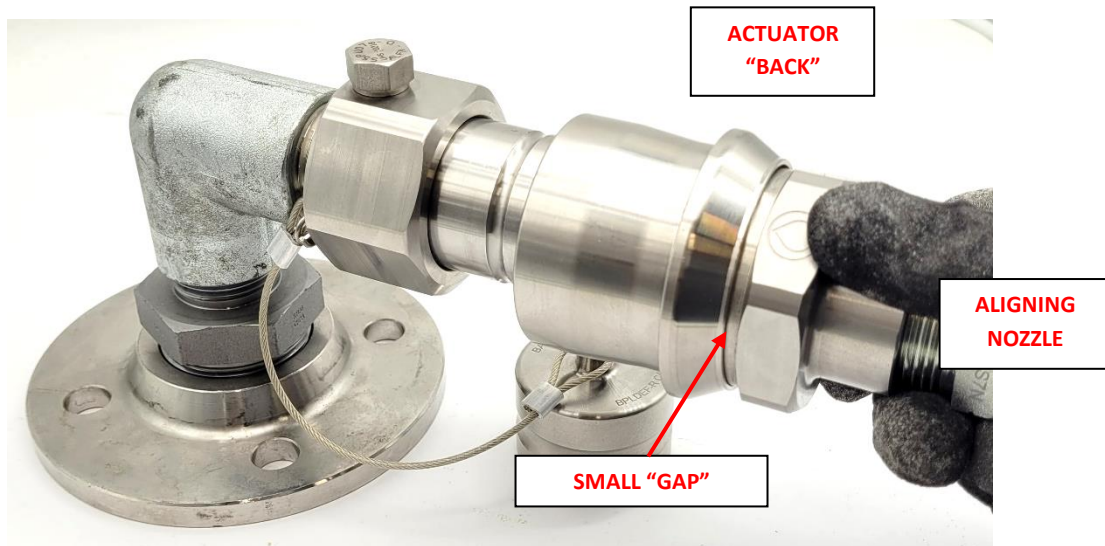

Figure 6 - "Locating" Nozzle Face *Concentrically* with Receiver

9. Once the Couplers are aligned and whilst holding only the **rear** (tail) of the Nozzle, securely push onto Receiver in one motion. Do **NOT** hold the Nozzle Actuator. Once the Couplers are aligned, and in **one** swift but smooth movement, push the Nozzle onto the Receiver. Latching of the ball locks occurs once the Nozzle Actuator moves **forward** (away from the operator/user). Do not release the Nozzle until **fully** engaged with the Receiver.

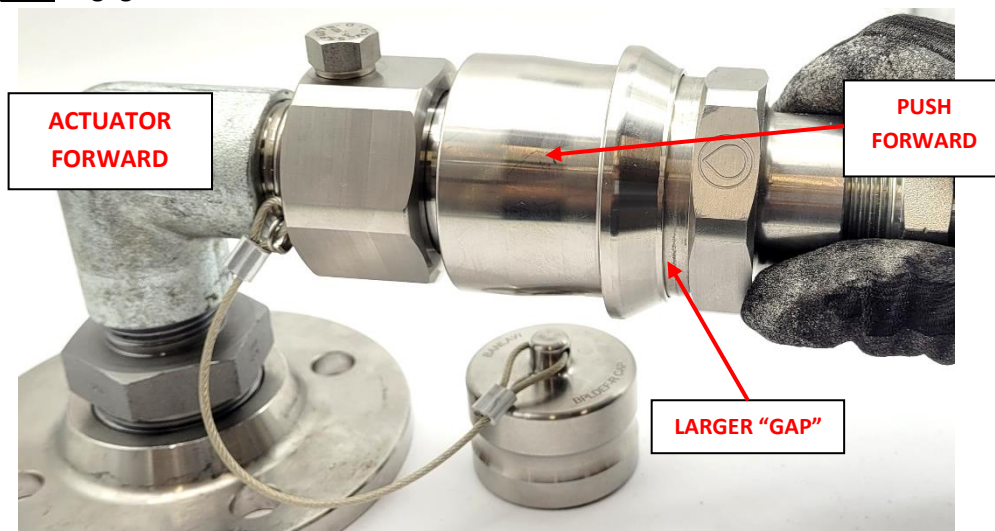

Figure 7 – "Push to Connect" - Couplers Connected

10. The ball lock mechanism is engaged once the Actuator moves into the fully forward position, creating a larger "gap" (clearance) between the rear of the Actuator and the Nozzle tail – refer Figure 7.
11. Pull back on **rear** (only) of the Nozzle to ensure a secure connection. If Nozzle disconnects, ensure no dirt and other contamination are within the ball lock groove of the Receiver, and repeat steps 3 to 10 until couplings are connected. Do **NOT** pull back on the Nozzle Actuator unless the Couplings are to be safely disconnected (refer from step 13).
12. If fitted and once the couplers are securely connected, ensure all bleed valves are closed, open the valve (if fitted) adjacent the Nozzle inlet, and start the supply pump to initiate Diesel Exhaust Fluid transfer. Supervise (monitor) fluid transfer process.

6.2 COUPLING DISCONNECTION

13. Once the Diesel Exhaust Fluid transfer is completed and **prior** to disconnecting the Couplers, **stop** (turn OFF) the DEF supply pump, and if fitted, **close** the manual isolation valve at the Nozzle inlet.
14. Using the designated fluid pressure bleed procedure, bleed all measurable pressure from within the Couplings.
15. Retract and hold back Nozzle Actuator and **steadily** remove Nozzle from the Receiver. Pull back on the Nozzle with one steady and smooth movement. **Hold the Nozzle Actuator back during the entire disconnection process.**

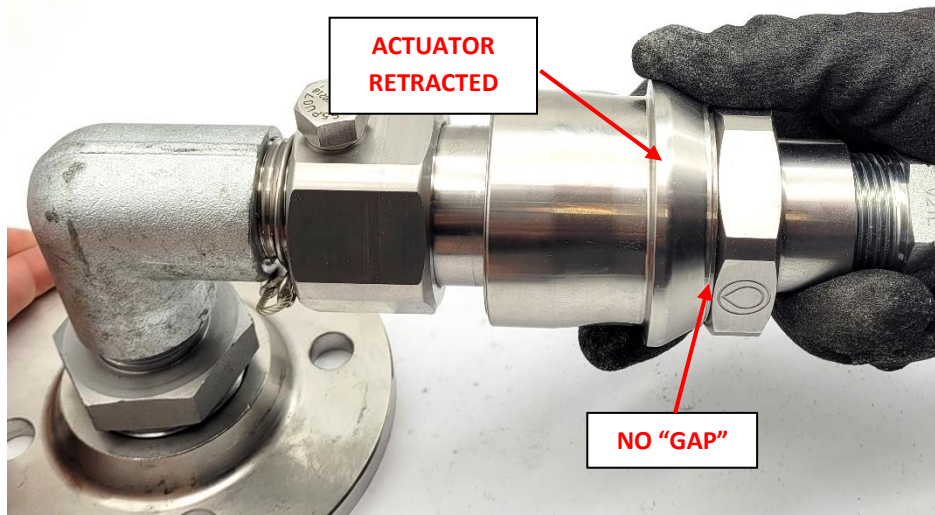

Figure 8 - Retracting Nozzle Actuator to Disconnect from Receiver

16. Once disengaged, release Actuator. Ensure both the Nozzle and Receiver return to their “normally closed” (sealed) state. If not, promptly repeat (only) steps 8, 9, 10 and 15. If either coupler still fails to close, promptly isolate any fluid supply to the faulty Coupler. Place this fluid transfer line “Out of Service” to prevent further use until the faulty Coupler is replaced.
17. Wipe any residual DEF from the receiver body face and then replace the Receiver Dust Cap. Ensure any bleed valves are closed and the fluid transfer system is otherwise left in a safe idle state.



Figure 9 – DEF Receiver Dust Cap Fitted

18. Wipe any residual DEF from the nozzle body face and then replace the Nozzle Dust Cap and safely return the Nozzle etc. by carrying them to their designated storage location, i.e. do **NOT** drag the Nozzle along the ground, or allow impact with any object.
19. **Ensure work area and all equipment are left clean and in a safe state.**
20. Ensure any faults or incidents identified during the fluid transfer are promptly reported for attention.

6.3 DEF COUPLING OPERATION OVERVIEW

- 1 ENSURE LIQUID DISPENSING SYSTEM IS SAFE AND AVAILABLE FOR USE
- 2 SAFELY BLEED RESIDUAL PRESSURE WITHIN NOZZLE (DISPENSING SIDE)
- 3 SAFELY BLEED RESIDUAL PRESSURE WITHIN RECEIVER (RECIPIENT SIDE)
- 4 REMOVE RECEIVER DUST CAP AND NOZZLE DUST CAP
- 5 WIPE FRONT OF EACH COUPLER CLEAN WITH RAG
- 6 FULLY (CONCENTRICALLY) ALIGN DEF NOZZLE WITH DEF RECEIVER
- 7 HOLDING *ONLY* THE NOZZLE "TAIL", PUSH ONTO RECEIVER UNTIL FULLY CONNECTED
- 8 PULL BACK ON NOZZLE "TAIL" TO ENSURE SECURE CONNECTION
- 9 START LIQUID DISPENSING PUMP/SYSTEM
- 10 COMPLETE THE REQUIRED LIQUID TRANSFER
- 11 TURN OFF LIQUID DISPENSING PUMP AND SAFELY BLEED RESIDUAL PRESSURE WITHIN COUPLERS
- 12 HOLDING WEIGHT OF NOZZLE, RETRACT NOZZLE ACTUATOR & DISCONNECT COUPLERS
- 13 REPLACE RECEIVER DUST CAP AND NOZZLE DUST CAP
- 14 RETURN NOZZLE AND ATTACHED EQUIPMENT TO STORAGE LOCATION
- 15 ENSURE THE LIQUID DISPENSING SYSTEM AND WORK AREA ARE LEFT IN A CLEAN & SAFE STATE

6.4 DIESEL EXHAUST FLUID (DEF) EVACUATION

1. The DEF Receiver has been designed with specific geometry that **DOES NOT** allow the DEF Receiver to couple with the Banlaw Evacuation Coupling (BEC-B). The DEF Receiver body is physically larger than the BEC-B Body bore, refer to Figure 10.

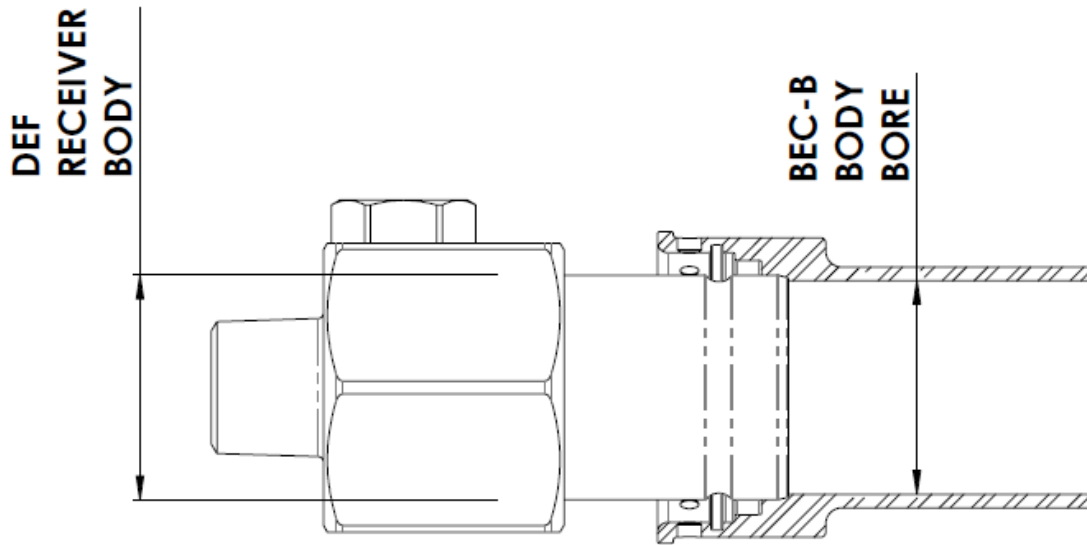

Figure 10 – DEF Receiver incompatibility with BEC-B

2. Should any Diesel Exhaust Fluid (DEF) / AdBlue® need to be withdrawn from the DEF reservoir/tank, the DEF Nozzle must be used as the mating Coupler to the DEF Receiver. The DEF nozzle can then be connected to a suitable vacuum pump and/or drain hose and drained into a suitable storage container.

6.5 DIESEL EXHAUST FLUID RECEIVER HEATER

1. Diesel Exhaust Fluid (DEF) / AdBlue® has a freezing point temperature of -11°C (12°F). To allow DEF transfer in a cold temperature environment, the DEF receiver can be fitted with DEF heater. The DEF heater is screwed into the port provided in the DEF receiver tail, refer to Figure 11.

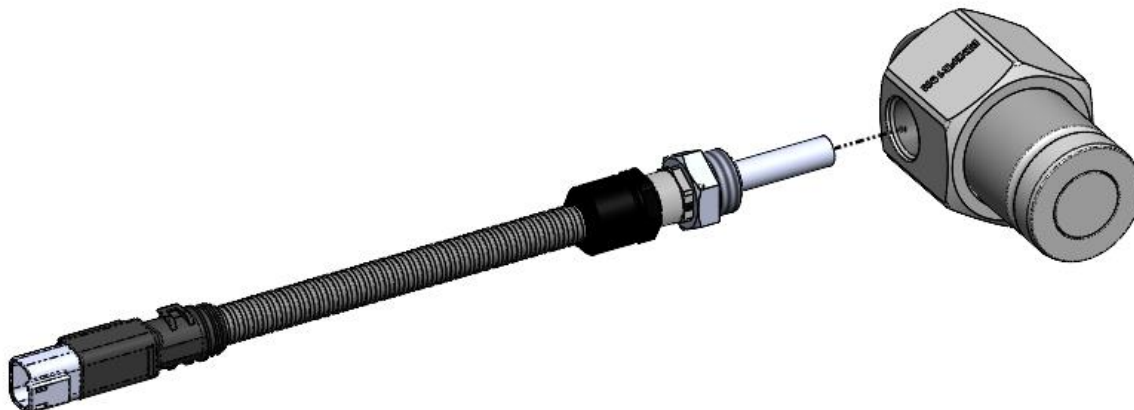

Figure 11 – DEF Heater fitment to DEF receiver

2. Refer to Table 3 for DEF Heater specifications:

Banlaw Part Number	BDEFHD
Operating Voltage	12 - 24VDC
Power Consumption	23W
Maximum In-rush current	3A
Resistance at 25°C (77°F)	16 - 32Ω
Maximum DEF Heater Surface Temperature	105°C (221°F)
Operating Temperature Range	-40°C to +55°C (-40°F to 131°F)
Ingress Protection (IP) Rating	IP67
Housing Material	Stainless Steel
Heater Port Thread	½" BSPP(M)
Harness Length	254mm (10")

Table 3 – DEF Heater Specifications

3. The DEF Heater is sold separately to the DEF receiver. If a DEF Heater is required, please ensure that both components are ordered. The DEF Heater is also available as a spare part.
4. The DEF Heater utilises a Positive Temperature Coefficient (PTC) heater element to prevent the DEF/AdBlue® from freezing. A PTC style heater has a specific temperature set point, as defined in Table 3. A PTC style heater also will increase its current proportionately with the temperature increase - meaning that the DEF heater will effectively ‘turn off’ as it approaches its design temperature.
5. The DEF Heater is fitted with a thermostat that only allows the Heater to operate in ambient temperatures below 5°C (41°F). In ambient temperatures above 5°C, the thermostat will be in open circuit and not allow the DEF Heater to operate. The thermostat is a set temperature and cannot be modified nor bypassed.
6. The DEF Heater is fitted to the DEF receiver by the following steps:
 - Remove and discard the blanking plug and its O-ring from the tail of the DEF receiver
 - Screw DEF Heater into the DEF receiver tail port, ensuring that the new supplied O-ring is fitted
 - Torque DEF heater to 24-27 Nm (18-20 ft-lbf)
 - Connect to appropriate 12 - 24VDC power supply, as defined in Table 3, utilising the 2-pin DT Series Deutsch receptacle fitted the DEF Heater. Refer to Figure 12 for DEF Heater electrical wiring details

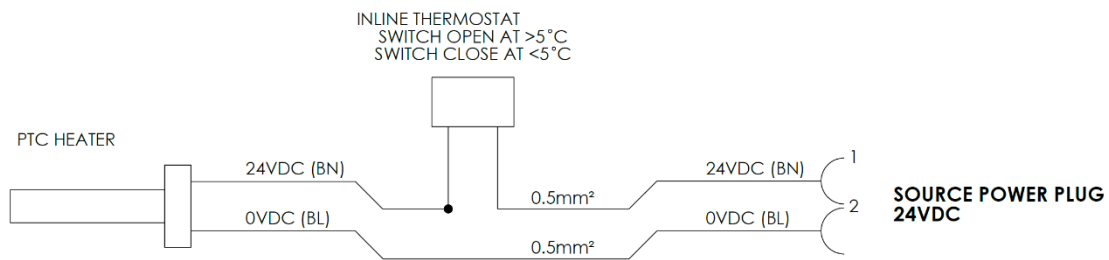

Figure 12 – DEF Heater electrical wiring details

7. Banlaw recommends that a 5A slow blow upstream fuse is fitted when wiring the DEF heater to the supply power.
8. To facilitate simpler field wiring, Banlaw offers a range of source power extension harnesses. These are supplied with a mating 2-pin DT Series Deutsch plug and 2 bare cores with a cable gland for termination into an appropriate power source. Refer to Figure 13 and Table 4 for details and ordering information.

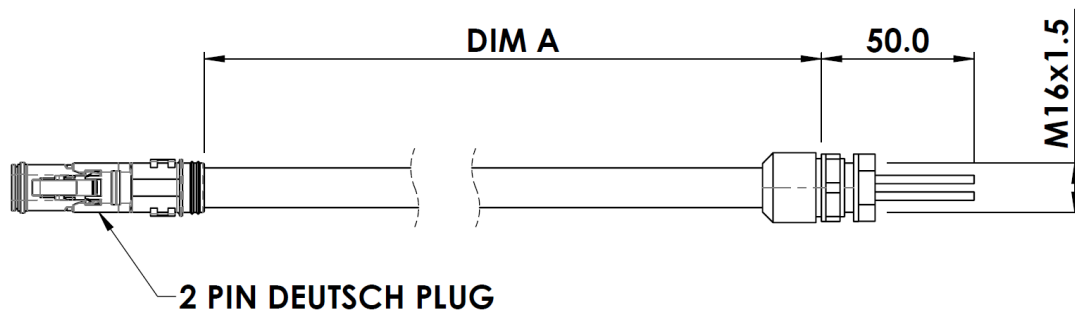

Figure 13 – Source Power Extension harness details

Banlaw Part Number	Description	Harness Length (DIM A)
BFSPHA05-2.5M	Source Power Extension Harness, 2.5m	2.5m
BFSPHA05-5M	Source Power Extension Harness, 5m	5.0m
BFSPHA05-7.5M	Source Power Extension Harness, 7.5m	7.5m
BFSPHA05-10M	Source Power Extension Harness, 10m	10.0m

Table 4 – Source Power Extension Harness ordering information

- Should the DEF Heater fail to heat correctly, or the wiring harness become damaged, please contact Banlaw immediately to arrange supply of a new DEF Heater.

6.6 DEF TRANSFER SYSTEM HEATING

- The optional DEF Heater, fitted directly to the DEF Receiver, will only assist with keeping the Diesel Exhaust Fluid (DEF) / AdBlue® above its freezing temperature locally to the fitted position of the DEF receiver within the DEF transfer system.
- If the DEF receiver is a remote fill location, i.e. fitted in an accessible location away from the DEF storage tank, the DEF Heater will ONLY heat the DEF receiver. The DEF Heater will NOT heat the remote transfer pipework or hoses to ensure the entire DEF transfer system is operational in cold climates. A heated DEF transfer line /hose will be required. This component is not available from Banlaw.
- If the DEF receiver is fitted directly to the DEF storage tank, the DEF Heater will ONLY heat the DEF receiver. The DEF Heater will NOT heat the entire DEF storage tank and its contents. A suitable DEF storage tank heating system will be required. This system is not available from Banlaw.
- Banlaw has designed an in-line DEF system heater adaptor that allow the DEF Heater to be fitted within the DEF transfer system. The DEF Heater Adaptor, BDEFHA001, is available separately for purchase and DOES NOT come supplied with a DEF Heater. An additional DEF Heater must also be purchased. Refer to Figure 14 and Section 6.7 for further details of the DEF Heater Adaptor.

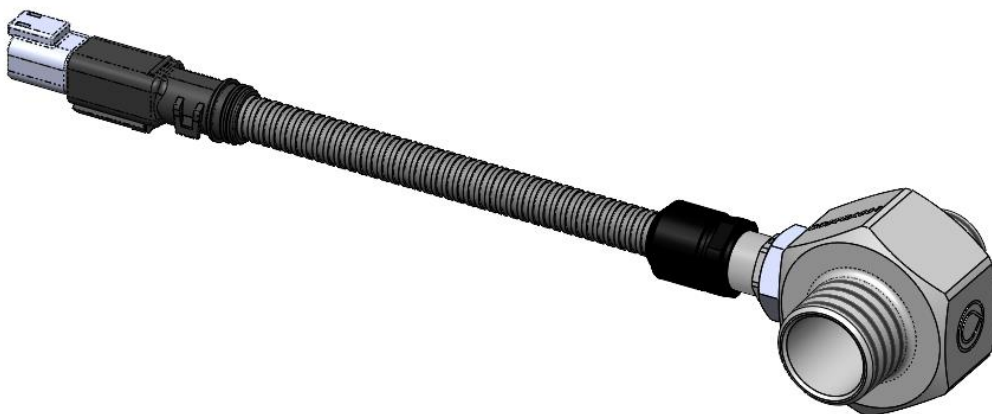

Figure 14 – DEF Heater (BDEFHD) fitted to DEF Heater Adaptor (BDEFHA001)

6.7 DEF SYSTEM ADAPTORS

To enable the Banlaw DEF couplings to integrate with existing DEF hardware already in service, a comprehensive range of DEF adaptors have been developed by Banlaw to allow simple DEF coupling replacement/conversion in the field.

All Banlaw DEF adaptors are manufactured from Stainless Steel and are supplied with DEF compatible seals and/or gaskets as appropriate.

Refer to below Table 5 and for details of available DEF adaptors:

Banlaw Part No.	Description	Connection Details	Application
BDEFA001 (Figure 15)	Adaptor, DEF, 3/4" NPT(F) x 1" BSPT(M)	3/4" NPT(F) 1" BSPT(M)	Adapts Banlaw DEF receiver to 1" BSPT(F) port and/or OFP components
BDEFA002A (Figure 16)	Adaptor Assy, Flange, Hartmann DEF Valve c/w O-Ring	Flange – Hartmann DEF Valve 3/4" NPT(F)	Replaces Hartmann DEF Valve with Banlaw DEF receiver and/or OFP components
BDEFA003A (Figure 17)	Adaptor Assy, Flange, Wiggins DEF Valve c/w Gasket	Flange – Wiggins DEF Valve 3/4" NPT(F)	Replaces Wiggins DEF Valve with Banlaw DEF receiver and/or OFP components
BDEFA004 (Figure 18)	Adaptor, DEF, Wiggins DEF receiver x 3/4" NPT(M)	3/4" NPT(F) 1-5/8" -12 UN male 1-5/16" -12 UN female	Adapts Banlaw DEF receiver to replace Wiggins DEF receiver
BDEFA005 (Figure 19)	Adaptor, DEF, 1-3/16" -12 UN(F) x 3/4" NPT(F)	3/4" NPT(F) 1-3/16" -12 UN female	Adapts Banlaw DEF receiver to Hartmann DEF valve
BDEFA006 (Figure 20)	Adaptor, DEF, 1-7/16" -12 UN(M) x 3/4" NPT(F)	3/4" NPT(F) 1-7/16" -12 UN male	Adapts Banlaw DEF receiver to replace Hartmann -16 DEF receiver
BDEFA007 (Figure 21)	Adaptor, DEF, 1-3/16" -12 UN(M) x 3/4" NPT(F)	3/4" NPT(F) 1-3/16" -12 UN male	Adapts Banlaw DEF receiver to replace Hartmann -12 DEF receiver
BDEFA008 (Figure 22)	Adaptor, Nipple, 1" BSPT(M) x 3/4" NPT(M)	1" BSPT(M) 3/4" NPT(M)	Adapts Flange Adaptor Assemblies to 1" BSPT(F) port and/or OFP components

Banlaw Part No.	Description	Connection Details	Application
BDEFA009 (Figure 23)	Adaptor, Nipple, 1-5/16" - 12 UN-O(M) x 1" BSPT(M) c/w O-Ring	1" BSPT(M) 1-5/16" -12 UN-O male	Adapts Banlaw DEF receiver to 1" BSPT(F) port and/or OFP components
BDEFHA001 (Figure 24)	Adaptor, DEF, Heater, 3/4" NPT(M) x 1" BSPT(M)	1" BSPT(M) 3/4" NPT(M) 1/2" BSPP(F)	Adapts Flange Adaptor Assemblies to 1" BSPT(F) port and/or OFP components. Additional 1/2" BSPP(F) port to accept DEF Heater

Table 5 – Banlaw DEF adaptor range

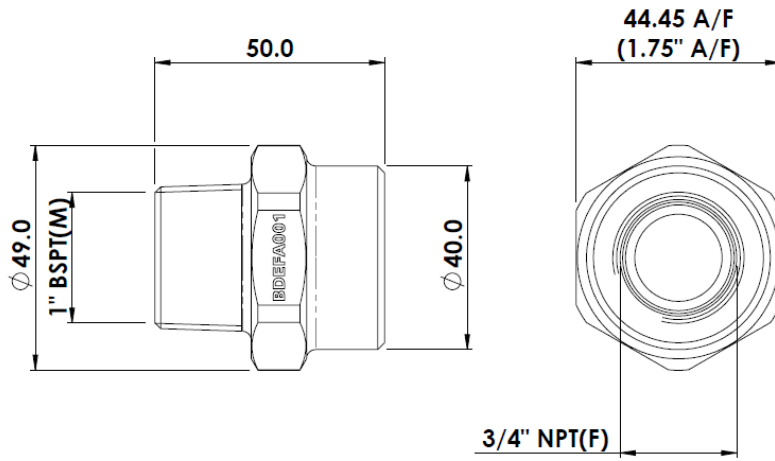

Figure 15 – Details of BDEFA001 Adaptor

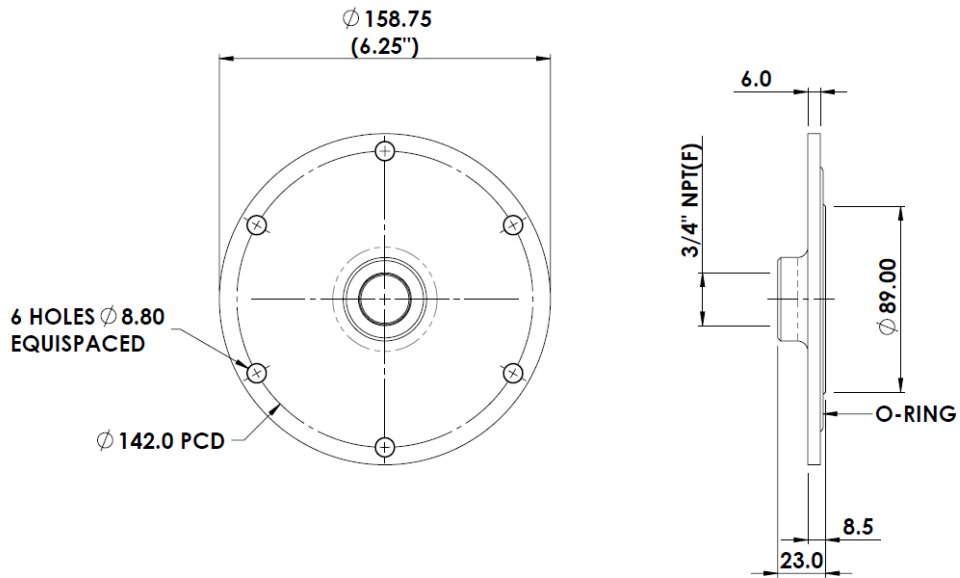

Figure 16 – Details of BDEFA002A Adaptor assembly

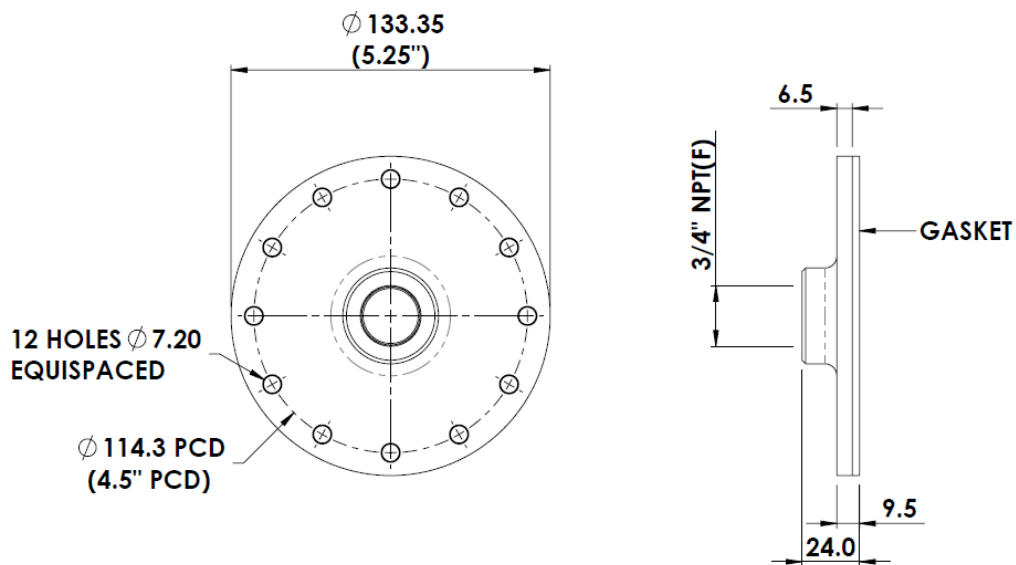

Figure 17 – Details of BDEFA003A Adaptor assembly

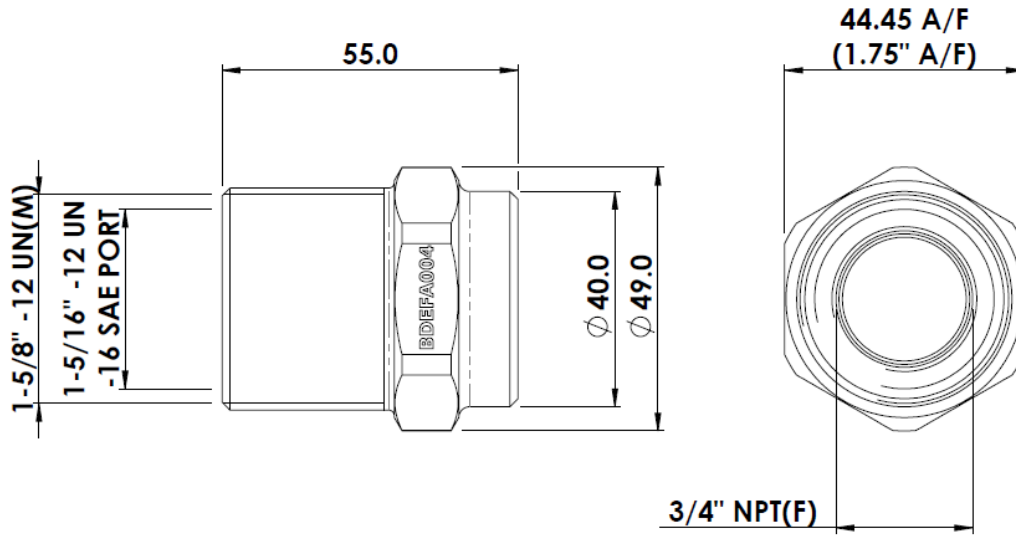

Figure 18 – Details of BDEFA004 Adaptor

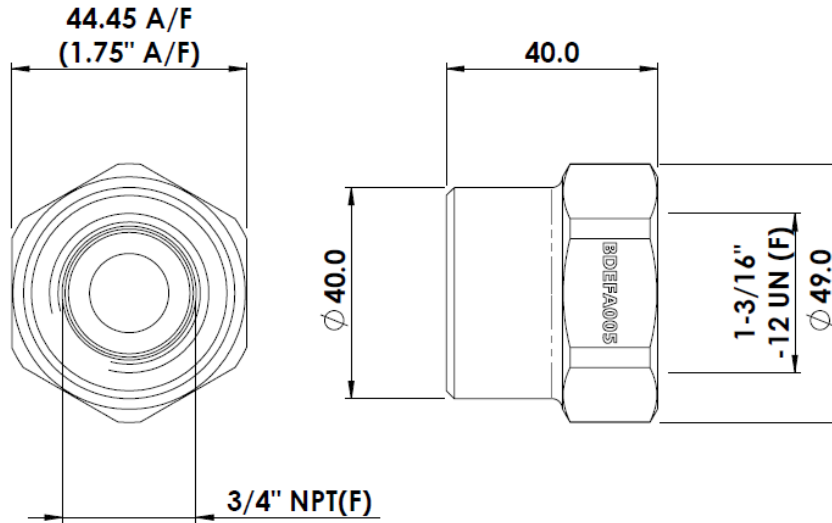

Figure 19 – Details of BDEFA005 Adaptor

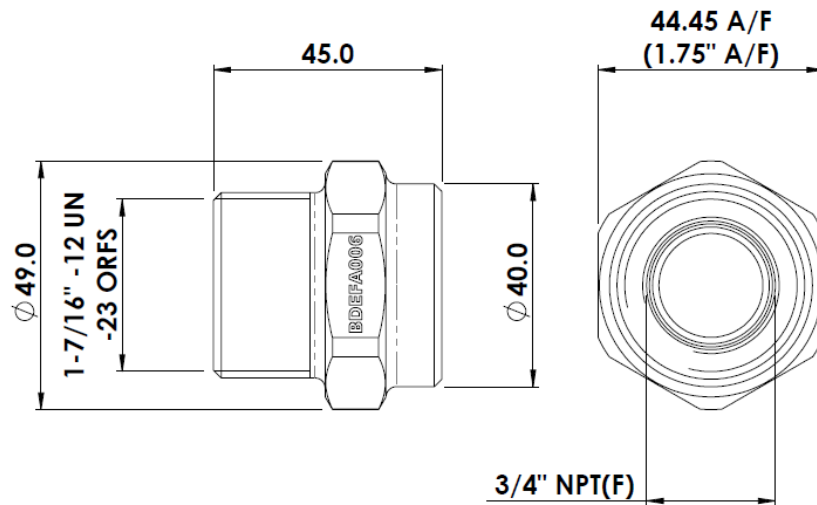

Figure 20 – Details of BDEFA006 Adaptor

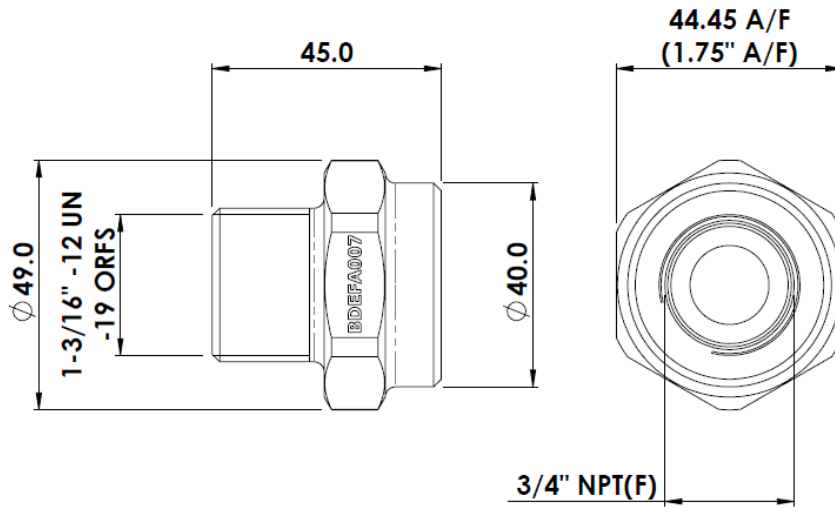

Figure 21 – Details of BDEFA007 Adaptor

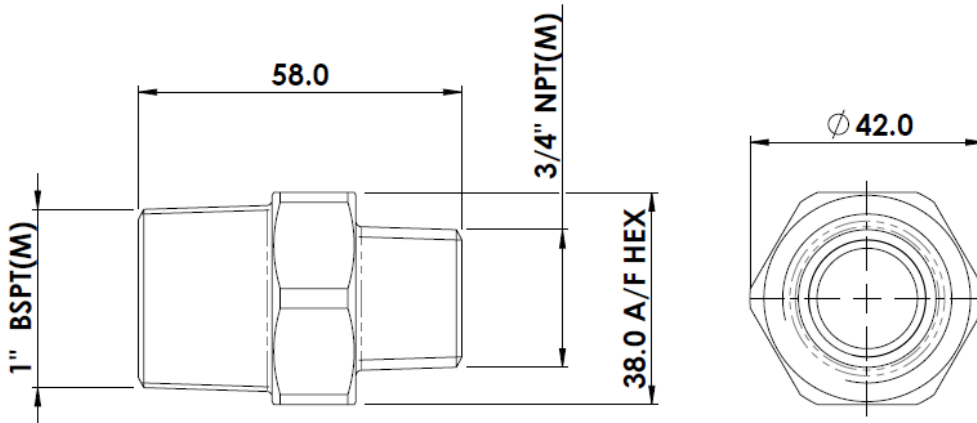

Figure 22 - Details of BDEFA008 Adaptor

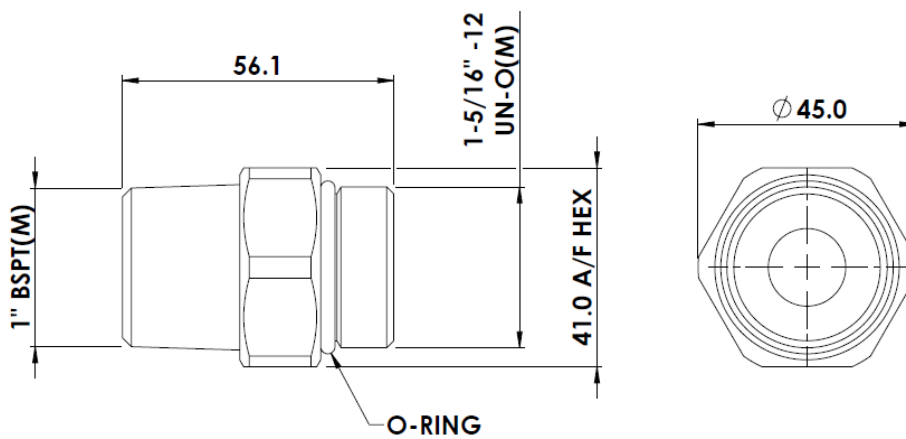

Figure 23 - Details of BDEFA009 Adaptor

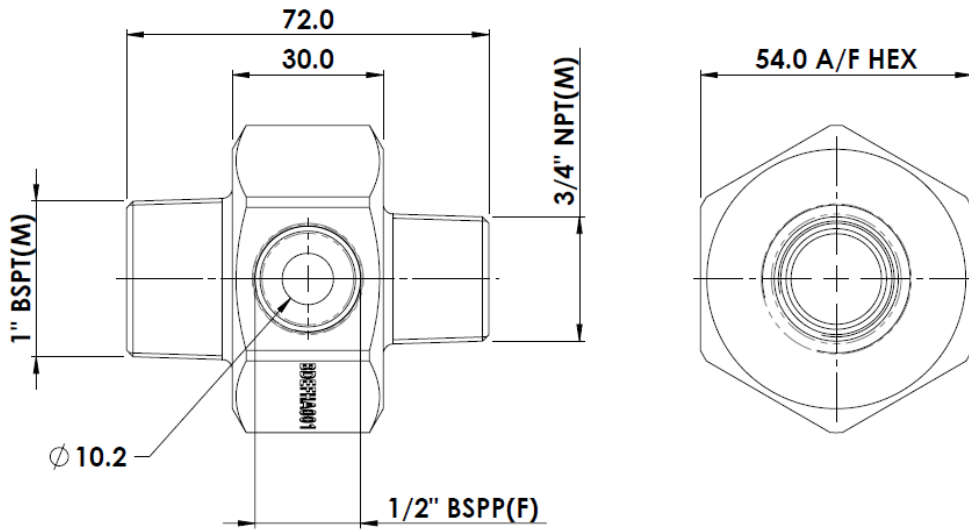

Figure 24 - Details of BDEFHA001 Heater Adaptor

7 MAINTENANCE GUIDELINES

This Maintenance Guide is general and is not meant to replace or override maintenance guidelines that arise out of a *due diligence* assessment of the Banlaw DEF Fluid Transfer Coupling for a specific liquid transfer application. For more detailed advice please contact Banlaw or your nearest authorised Banlaw distributor.

The following *preventative maintenance* guidelines apply to the DEF transfer Coupling;

- Inspect DEF Couplers and other liquid dispensing equipment prior to use for damage, excessive leakage or some other defect which may affect the safe use of the dispensing system.
- **Do NOT store a DEF Nozzle on the ground, or otherwise in an area prone to excessive contamination or possible damage.** Ensure there is provision to safely store the Nozzle off the ground, and with the liquid dispensing hose not left laying within plant equipment or operator thoroughfares.
- Due to the corrosive nature of Diesel Exhaust Fluid (DEF), ensure that when the DEF Nozzle is stored that any potential drips/residual DEF cannot fall or contact any equipment or personnel. The use of DEF Nozzle dust cap will assist in reducing the likelihood of this occurring.
- **Prior** to use, wipe away residual liquid and contamination (such as DEF crystallisation) from all mating surfaces of the DEF couplers (Nozzle & Receiver). This will not only reduce the ingress of contamination into the liquid stream, but also help to avoid accelerated wear & tear of the couplers.
- **To reduce the incidence of DEF crystallisation occurring ensure the DEF coupling Dust Caps, for both the DEF Nozzle and the DEF Receiver are used.** The use of Dust Caps will also reduce the risk of damage to the Coupling from impact when not in use.

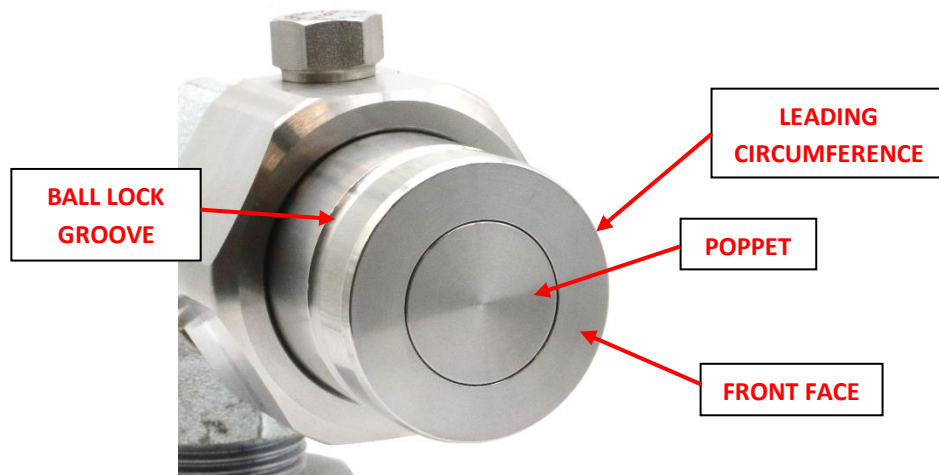

Figure 25 - Critical Areas of Damage on DEF Receivers

- **Closely** inspect the front area of the DEF Receiver (Figure 25) and DEF Nozzle (Figure 26) for excessive wear or damage;
 - DEF Receiver;
 - Wear to ball lock groove.
 - Damage and excessive wear to leading edge and front face.
 - Fluid leakage from front face.
 - Failure of the Poppet to return “flush” (fully forward, closed).

- DEF Nozzle;
 - Damage and excessive wear to leading edge and front face. Importantly, distortion of the leading edge of the Actuator may affect its required motion (action) and jeopardise the safety of the Nozzle.
 - Fluid leakage from front face or from between Actuator and Tail.
 - Failure of the Piston to return “flush” (fully forward, closed).
- Promptly replace any faulty DEF couplings prior to their next required use or place the coupler(s) “Out of Service” until replacement.
- **Closely** inspect the front area of the DEF **Nozzle** (refer Figure 26), for signs of damage or excessive wear & tear. Excessive wear or damage may cause problems connecting and disconnecting the couplers but will also introduce the risk of unintentional coupler disconnection – i.e. DEF Nozzle “fly off” – during pressurised liquid transfer. Promptly replace any faulty DEF couplers prior to their next required use or place the coupler(s) “Out of Service” until replacement.

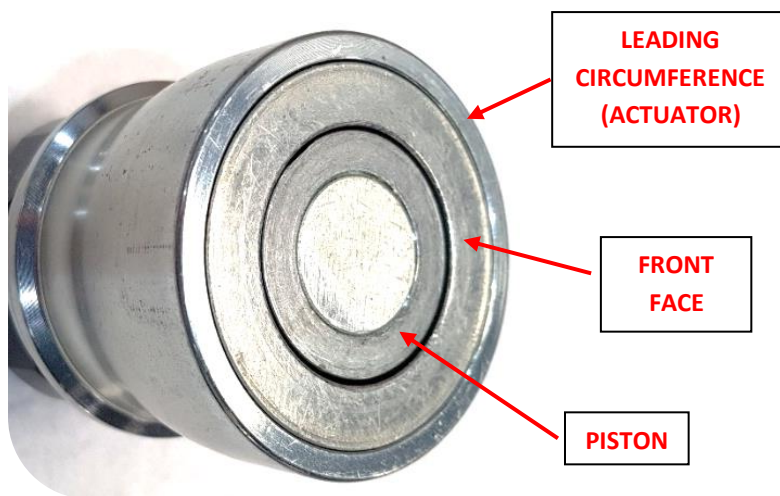

Figure 26 - Critical Areas of Damage on DEF Nozzles

7.1 DEF COUPLING SPARE PARTS

The Banlaw DEF Couplings are ***non-serviceable*** items. The following genuine Banlaw spare parts are available to suit this product. **The use of non-genuine parts, or the dismantling, misuse or tampering of this product may cause improper and unsafe function, serious safety hazards, and void Banlaw warranty.** Please see www.banlaw.com for warranty details and a full list of distributors near your area to source genuine Banlaw replacement spares and new products.



Item Description	Banlaw Part Number	Image
DEF Nozzle Dust Cap	BDGNC	 A line drawing of a circular dust cap with a small nozzle attached to a thin cable. The cap has the word 'BANLAW' printed on it.
DEF Receiver Dust Cap	BDEFRC	 A line drawing of a cylindrical dust cap with a small nozzle attached to a thin cable.
DEF Heater	BDEFHD	 A line drawing of a long, flexible heater cable with a metal fitting at one end and a connector at the other.

Table 6 – DEF Coupling Spare Parts

8 PRODUCT RECYCLING & DISPOSAL

Banlaw values and supports the sustainable use of resources, and the safe, responsible and proper disposal or recycling of all materials within its products. For a description of the principal materials within a DEF coupling, please refer to section 3.

9 PRODUCT WARRANTY

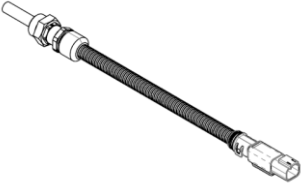
Banlaw is committed to providing quality products and services. To provide further assurance, our products and services are backed by generous warranties.

A copy of the Banlaw product warranty terms and conditions is available from Banlaw, the Banlaw website, or your nearest authorised Banlaw agent.

END OF DOCUMENT

Website – www.banlaw.com