

***Banlaw LubeCentral™***  
***GTX Grease Couplers – Nozzle and Receiver***

Thank you for purchasing this high quality Banlaw product. Please read through and understand the information in this Product Data Sheet (PDS) BEFORE installation or operation to avoid accidental personal injury or property damage.

**1 PRODUCT DESCRIPTION**

The unique range of Banlaw LubeCentral™ “Flush-Face” Grease Couplers are designed for the pressurised transfer (e.g. dispensing) of **greases** commonly used in the mining, rail, port and transport industries. These innovative Couplers incorporate features<sup>#</sup> to markedly improve levels of **safety, ease of operation, contamination control,** and **durability** when compared with other grease transfer couplers used for similar applications. A “standard” series is available for non-arctic environments, and an “Arctic” series is available for extreme cold temperature environments.

<sup>#</sup>This product is subject to patents and patents pending. Please see [www.banlaw.com](http://www.banlaw.com) for details.



**Figure 1 - GTX Grease Couplers**

Figure 1 illustrates examples of GTX Grease nozzle, receiver and receiver dust cap;

- (Top Left); GTX Grease “Nozzle” (female coupler).
- (Middle Right and Bottom); GTX Grease “Receiver” (male Coupler) and Dust Cap.

## 2 IMPORTANT RESTRICTIONS ON THE USE OF THIS PRODUCT



1. The safe installation and subsequent operation of a Banlaw product relies on the completion of all necessary *“due diligences”* for the assessment of the Banlaw product(s) being suitable for the intended application(s). Such an assessment is best achieved through the cooperation of the supplier/OEM (Banlaw) and the customer or end-user. Once such an assessment deems the Banlaw product(s) to be suitable, the customer or end-user shall ensure effective *“change management”* applies should any prominent or influential aspect of the application (upon which the initial assessment was based) be subject to change and may affect the ongoing suitability (i.e. safety and proper function) of the Banlaw product.
2. The Banlaw LubeCentral™ Grease Couplers incorporate **external** components manufactured from **aluminium**. Products containing **external (exposed) aluminium** are typically unsuitable for use within an underground coal mine, or otherwise within an area where the use of external aluminium components (or other materials within the product) are prohibited for use in accordance with applicable governances.



1. Unless noted otherwise by Banlaw, the Banlaw LubeCentral™ Grease Couplers have *not* been assessed under any Regulatory or Industry Standard, Code, Directive, Guideline or other governance which may apply to the use of this product in specific applications. Please consult Banlaw prior to installation if in doubt.
2. The GTX Couplers are unique fluid couplers, i.e. a GTX Nozzle is designed and intended only for use with a compatible GTX Receiver. No attempt should be made to engage a GTX coupler with an alternative incompatible fluid coupler or other attachment.
3. The Banlaw LubeCentral™ Grease Couplers are designed for use with **clean** greases (mineral and synthetic) up to grease consistency number NLGI-2, (i.e. grease grades NLGI-2 and lower). The GTX Couplers have *not* been tested with greases above NLGI-2 grade, nor with other liquid (incompressible fluid) types. **Please contact Banlaw *prior to the use of this product with other (foreign) liquids.***
4. Particularly for the “Arctic” coupler range, changes in the physical properties (e.g. thickening or “caking”) of the grease at low temperatures may cause reduced functionality of the couplers.

### Note:



This product is unsuitable for use with AdBlue (DEF) or with an alternative fluid (or substance) whose properties may affect the safety, function or reliability of the product. Please consult with Banlaw to confirm fluid compatibility if in doubt.

### 3 PRODUCT SPECIFICATIONS



For GTX Coupler **dimensions** and the **Part Numbers** of the various GTX Couplers and accessories available, please refer to the relevant Banlaw Product Specification Guide (PSG), the Banlaw website, or contact Banlaw or your nearest Banlaw authorised distributor.

GTX Coupler Configuration	Safe Working Pressure (SWP)	Minimum Burst Pressure (BP)
<b>“Standard” (Non-Arctic) Couplers</b>		
Nozzle (female Coupler) only	25MPa (3,626psi)	100MPa (14,503psi)
Receiver (male Coupler) only	8.9MPa (1,291psi)	35.6MPa (5,163psi)
Nozzle and Receiver Connected	20MPa (2,900psi)	80MPa (11,603psi)
<b>“Arctic” Couplers</b>		
Nozzle (female Coupler) only	15.4MPa (2,234psi)	61.6MPa (8,934psi)
Receiver (male Coupler) only	9.4MPa (1,963psi)	37.6MPa (5,453psi)
Nozzle and Receiver Connected	19MPa (2,756psi)	76MPa (11,022psi)

**Table 1 - Operating Pressures**

Operating Temperature Range °C (°F)	“Standard” GTX Couplers; -10 to 55°C (14 to 131°F) “Arctic” GTX Couplers; -40 to 55°C (-40 to 131°F) ##
Max. Recommended Temperature	120°C (248°F) – <b>after</b> risk assessment
Max. Recommended Flowrate	30kg/min (66lb/min)
Compatible Fluid Types	<b>Clean</b> greases NLGI-2 consistency (grade) and below
Principal Material Composition	Zinc Plated Steel, Anodised Aluminium, Viton®, fluorosilicone ( <i>arctic</i> series only)

**Table 2 - Operating Specifications**

**Legend:**“SWP”; Maximum recommended Safe Working Pressure

“Max.”; Maximum (upper limit)

“Min.”; Minimum (lower limit)

## This temperature range refers *only* to the “Arctic” series GTX Couplers.

- Notes:**
1. All pressure data refers to the **internal** fluid pressure, where each product is in “as new” condition.
  2. All Burst Pressures tested at approx. 25°C (77°F) ambient temperature.
  3. The “Arctic” range of couplers have been pressure tested to their SWP at -40°C (-40°F).
  4. All data is subject to a tolerance (variation) due to inherent, typical changes in the mechanical properties of materials of construction.

## 4 KEY FEATURES

The GTX Couplers incorporate the following key features;

- **“Dry-Break”** (normally closed) function.
- **“Push to Connect”** operation, i.e. the Nozzle actuator (collar/sleeve) does not need to be manually retracted to engage the Nozzle with a GTX Receiver – the Couplers are simply “pushed together”.
- **“Flush-Face”** design, markedly reducing the opportunity for contamination ingress and build-up into the Couplers and the grease stream. Residual contamination can be cleared using a clean rag.
- **“Ball Lock Latching Mechanism”**; typically considered the most secure means of fluid coupler mechanical “latching” (connection).
- **“Robust Construction”**; manufactured from materials suited to harsh operating conditions – key structural and wearing parts are manufactured in zinc plated higher strength carbon steels.
- **“Matching Couplers”**; as with the Banlaw BPL coupler range, the GTX Couplers have been designed to only engage with the correct (mating) Coupler, virtually mitigating the risk of fluid cross-contamination. Colour coding of “matching” Couplers provides a visual means of Coupler identification.
- **“Connect Under Residual Pressure” (GTX Nozzles)**; the GTX Nozzles may be safely connected to a GTX Receiver whilst *residual*<sup>###</sup> fluid pressure remains within the Nozzle.



<sup>###</sup> The “connect under residual pressure” feature of the Nozzle is often misinterpreted, resulting in the **incorrect and potentially unsafe operation of the couplers**. The objective or intent of this feature does **not** include the operation of couplers under the following conditions which may cause hazards such as the pressurised ejection of grease from the couplers, or malfunction of a coupler;

- The fluid supply pump (or other fluid supply means) connected to the nozzle inlet remaining running (operating), with no other means available to fully isolate the pressurised supply from the Nozzle inlet until the couplers are fully (properly) engaged. Put simply, any fluid supply which promotes the **pressurised flow** of fluid to the Nozzle inlet prior to coupling connection does not fall under the intent of the “connect under residual pressure” feature. The key term is “residual”, analogous to the “hydraulic lock” of pressurised static liquid within the nozzle.
- Any attempt to disconnect the couplers whilst any measurable degree of residual pressure remains within the mated couplers.

## 5 INSTALLATION AND COMMISSIONING GUIDELINES

This Installation and Commissioning Guide is general and is not meant to replace or override installation guidelines that arise out of a *due diligence* assessment of a Banlaw product for a specific (intended) application.

### 5.1 Pre-Installation Guidelines



- Any proposed installation/application/operation of the Banlaw GTX Couplers shall satisfy the Specifications detailed in section 3, and other requirements within this document. As grease transfer is typically conducted at relatively high liquid pressures, the specifications for any other parts and equipment included within this install must also comply with the parameters (e.g. pressure, temperature, flowrate, etc.) of the application. ***Failure to ensure the GTX Couplers and other equipment are used strictly in accordance with their applicable specifications will introduce potentially serious safety hazards.***
- This Product shall only be used by ***competent persons***, trained and/or directly supervised in their safe and proper operation.

The use of an isolation valve (e.g. manual ball valve) ***adjacent the GTXN Nozzle inlet*** is recommended to ensure the requirements of the ***“connect under residual pressure”*** feature of the Nozzle is met – refer section 4. The use of a Swivel – typically upstream of the Valve – is also recommended - refer Figure 2.

#### 5.1.1 GTXN Nozzle – Dispensing/Supply Side



The manual effort required to connect and disconnect these GTX Couplers has been minimised as far as is practicable, however the operation of the GTX Couplers must consider ***ergonomics*** to avoid potentially serious work health and safety (WHS) hazards. I.e. the way in which the Couplers are used for ***each*** intended application must be part of a pre-installation due diligence assessment. Difficulty in the manual handling of the GTX couplers and the remaining grease dispensing system equipment may not only introduce such WHS hazards, but also create a neglect to perform a grease dispensing operation due to such difficulties. Key manual handling tasks are likely to include;

- Operation of the manual valve(s).
- Carriage of the grease dispensing hose and dispensing equipment to and from the storage location and the grease service point (i.e. GTXR Receiver location).
- Connection of the GTX Couplers, particularly at extended reach.
- Disconnection of the GTX Couplers, particularly at extended reach.

#### Note:



To improve ease of use (ergonomics) in the event the GTXR Receiver is installed at a height above (human) chest height (i.e. approx. 1.2m, 4'), end-users may benefit from the installation of an ***elbow*** (i.e. whether 45° or 90°) between the Valve outlet and the GTXN Nozzle inlet – as noted in Figure 2.

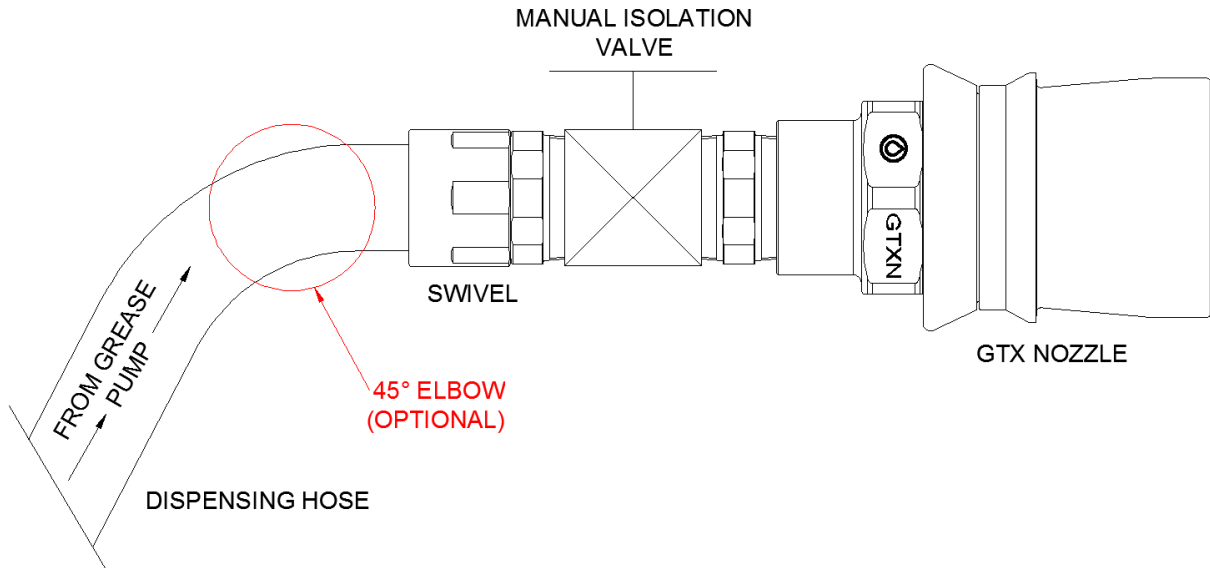

Figure 2 - Example of Grease Dispensing Arrangement with GTXN Nozzle

5.1.2 GTXR Receiver – Plant Equipment Side

The requirements of the “connect under residual pressure” feature of the Nozzle also rely on the lack of appreciable grease pressure within the GTXR Receiver and subsequent grease line into the downstream reservoir. Bleeding of residual pressure is best achieved using a manual bleed valve adjacent the Receiver outlet. Inclusion of a Pressure Gauge will assist operators identifying the degree of residual pressure. Figure 3 illustrates the basic elements of a recommended GTXR Receiver installation (Receiver Dust Cap not shown).

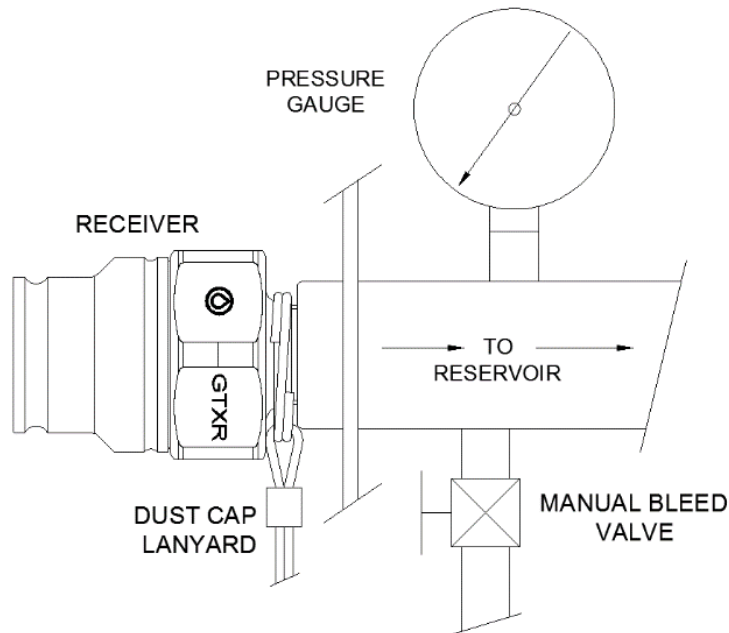

Figure 3 - Example of Grease Servicing Arrangement with GTXR Receiver



To improve ease of use (ergonomics) in the event the GTXR Receiver is installed at a height above (human) chest height (i.e. approx. 1.2m, 4’), end-users may benefit from the installation of an **elbow** (i.e. whether 45° or 90°) between the Receiver outlet and the inlet to the grease reservoir service point. An illustration is provided in Figure 4.

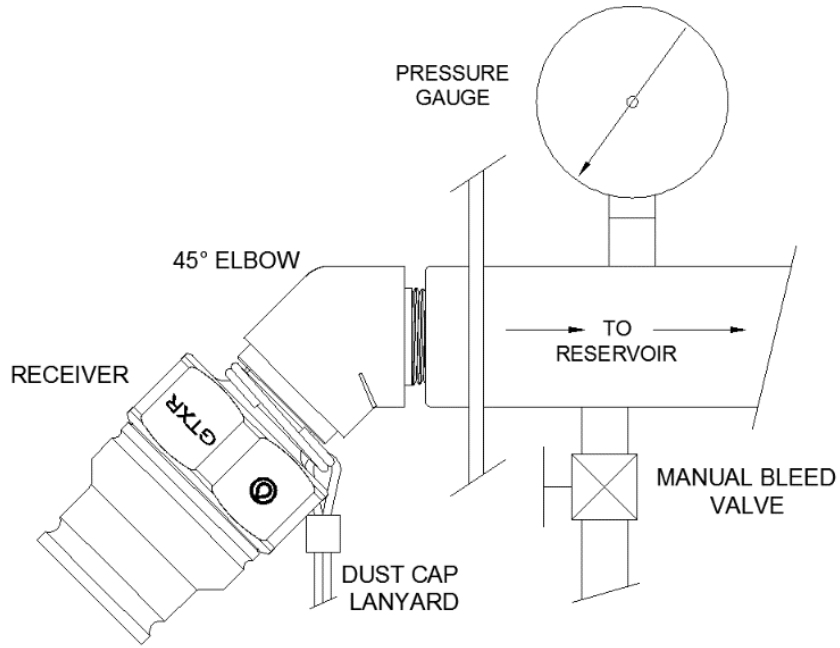

Figure 4 - Example of Grease Servicing Arrangement with GTXR Receiver and Elbow

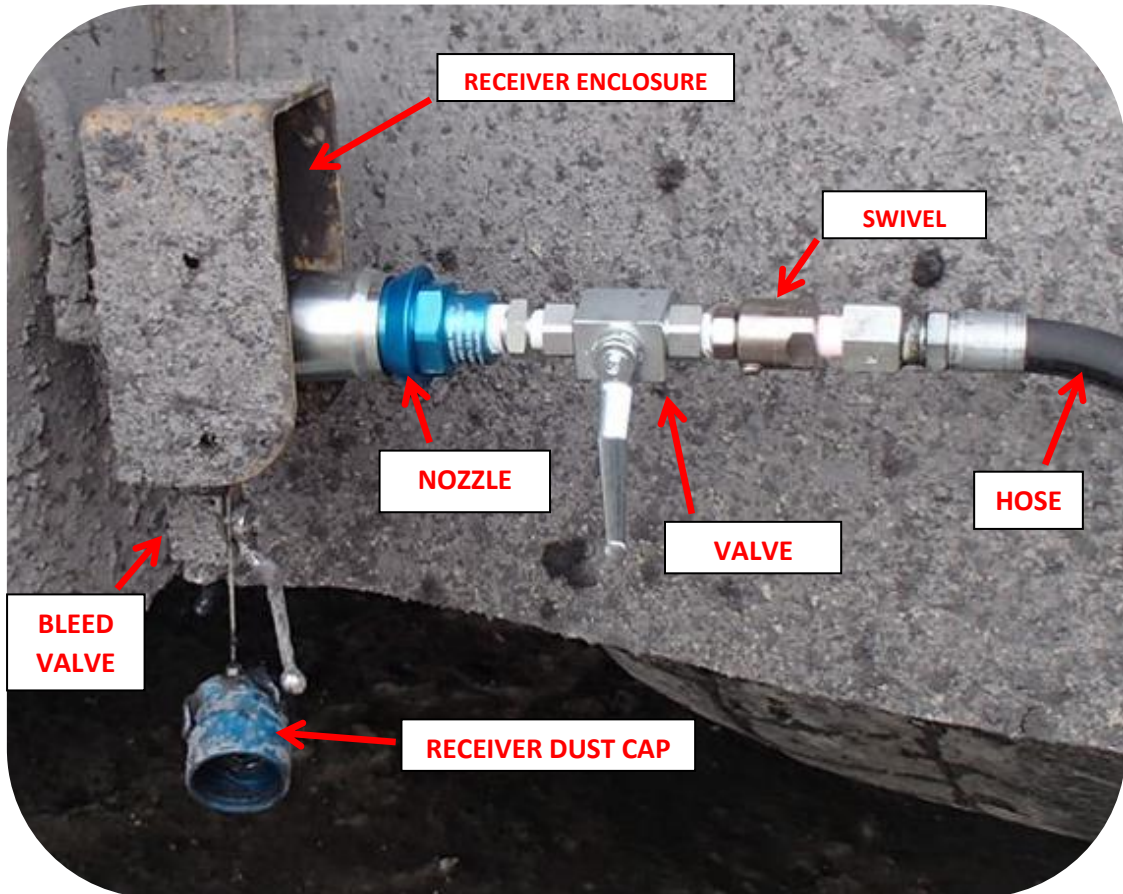

Figure 5 - Example of Grease Dispensing System with GTX Couplers Connected

## 5.2 Installation Guidelines

### Note:



#### General Installation Notes;

1. Conduct a **Job Hazard Analysis (JHA)** *prior* to install to mitigate health, environmental and equipment hazards.
2. Do **NOT** install any parts that are damaged or are otherwise faulty.
3. Do **NOT** install parts which are not compatible with mating parts.
4. Conduct all necessary measures to **prevent the ingress of contamination** into the GTX Couplers and other parts.
5. Only engage threads of the same thread type. Ensure all threaded connections are clean and in good condition. Avoid over-tightening.
6. An appropriate thread sealant is recommended on NPT threaded process connections. Use **sparingly** and avoid excess use of Loctite and similar products – *residual thread sealants etc. may cause contamination and malfunction of the Couplers.*
7. Use only proper **hand tools** for the installation of all components – e.g. 2” spanner for GTXN Nozzles and 54 mm deep socket (e.g. BPLR SOCKET) for GTXR Receivers. Avoid the use of power or impact tools, and adjustable wrenches (e.g. Stillsons).
8. Use consumables (e.g. Loctite products) strictly in accordance with the OEM Safety Data Sheet (SDS) and operating guidelines. Do not use consumables beyond their expiry date.
9. Ensure all likely **energy sources** – e.g. grease pressure – are appropriately isolated and/or eliminated *prior* to installation of GTX Couplers and other parts.
10. Ensure all **Dust Cap** lanyard “split rings” are secured to the threaded process (outlet) connection of each Coupler during installation, or otherwise secured to a location adjacent the Couplers.

## 6 BASIC OPERATING INSTRUCTIONS



- Do **NOT** attempt to either connect or disconnect the GTX Couplers whilst ever;
  - a. The supply pump remains running (on) and is *not* positively isolated from the Nozzle or Couplers.
  - b. Residual grease pressure remains within the GTXR Receiver.
- Do **NOT** attempt to connect (use) a GTX Coupler with any non-compatible fluid Coupler or other fitting.
- Do **NOT** operate a GTX Coupler or any other fluid evacuation equipment that is damaged or otherwise faulty and potentially unsafe for use.
- Do **NOT** make any attempt to connect GTX Couplers without first removing residual grease and contamination from mating surfaces of each Coupler.
- Do **NOT** make any attempt to open a GTX Coupler by any means other than connecting with a mating GTX Coupler. For example, no attempt shall be made to bleed residual grease pressure from a GTX Coupler by manually opening a Coupler, or loosening the process connection to a Coupler – instead use a dedicated bleed valve.

How the GTX grease couplers are connected (engaged) and disconnected (disengaged) is the same as other similar industry “push to connect” fluid couplings incorporating a ball-lock style latching mechanism – e.g. the remaining Banlaw BPL range of fluid transfer Couplers.



1. Unless specific site (application) grease dispensing procedures dictate otherwise, ensure the grease supply pump is OFF (i.e. not running) prior to Coupler connection.
2. Retrieve the GTXN Nozzle, manual valve, swivel (if installed) and grease dispensing hose from their designated storage holster. Inspect all such equipment for signs of grease leakage, damage or other defects. Safely **carry** the equipment over to the GTXR Receiver, i.e. the grease servicing point – do **NOT** drag the GTXN Nozzle, manual valve or swivel along the ground.
3. Ensure the manual valve adjacent the GTXN **Nozzle** inlet is in the OFF (closed) position.
4. Using the designated bleed valve, ensure the GTXR **Receiver** and attached grease line is bled to remove residual pressure. **Leave the bleed valve open until after coupler connection** – refer step 11.
5. Remove Dust Cap (if fitted) from GTXN Nozzle. Remove any residual grease and contamination from the front face of the Nozzle using a clean rag.
6. Remove Dust Cap from GTXR Receiver. Remove any residual grease and contamination from the Receiver using a clean rag.
7. Whilst supporting the weight of the Nozzle etc. concentrically **align** the GTXN Nozzle with the GTXR Receiver, “feeling” the front end of the Receiver fit within the shallow recess on the mating face of the Nozzle – refer Figure 6.
8. Whilst holding only the **rear** (tail) of the Nozzle, securely push onto Receiver in one motion. **Do NOT hold the Nozzle Actuator**. Once the Couplers are aligned, and in **one** swift but smooth movement, push the Nozzle onto the Receiver. Latching of the ball locks occurs once the Nozzle Actuator moves **forward** (away from the operator/user). **Do not release the Nozzle until fully engaged with the Receiver**.

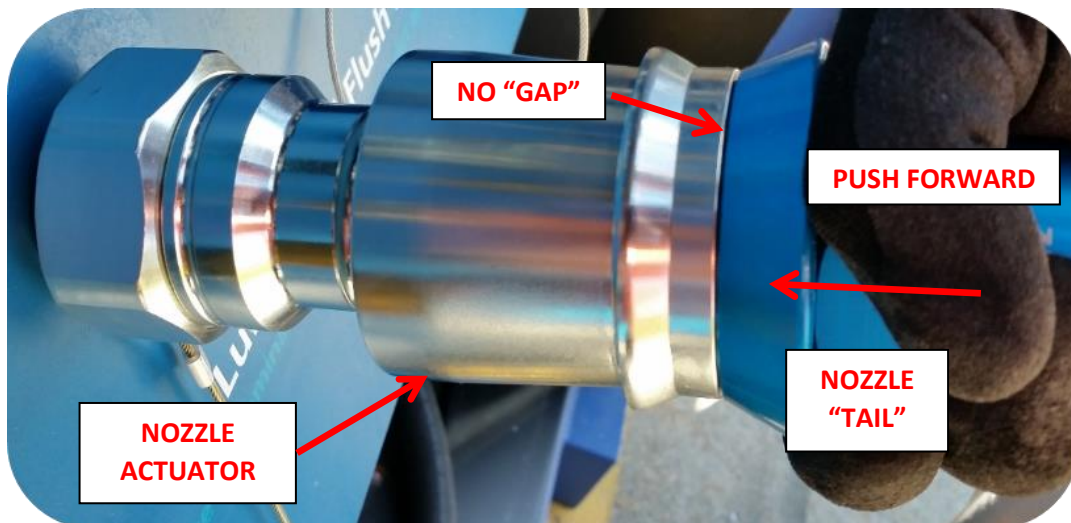

Figure 6 - Connecting the Couplers - "**Push to Connect**"

9. The ball lock mechanism is engaged once the Actuator moves into the fully forward position, creating a “gap” (clearance) between the rear of the Actuator and the Nozzle tail – refer Figure 7.
10. Pull back on rear of the Nozzle to ensure a secure connection. If Nozzle disconnects, ensure no dirt and other contamination are within the ball lock groove of the Receiver, and repeat steps 3 to 9 until couplings are connected. Do **NOT** pull back on the Nozzle Actuator unless the Couplings are to be safely disconnected (refer step 12 and on).
11. Once the couplers are securely connected;
  - a. **Close** the bleed valve behind the GTX Receiver.
  - b. **Open** the manual isolation valve adjacent the Nozzle inlet and start the supply pump to initiate grease transfer.



**Figure 7 - Couplers Fully Connected**

12. Once grease transfer is completed and **prior** to disconnecting the GTX Couplers;
  - a. **Stop** (turn OFF) the grease supply pump and **close** the manual isolation valve at the Nozzle inlet.
  - b. **Open** the Receiver side bleed valve, i.e. valve adjacent Receiver outlet to relieve residual pressure within the receiver and/or grease line leading to the downstream reservoir.
13. Retract and hold back Nozzle Actuator (Figure 8) and **steadily** remove Nozzle from the Receiver. Pull back on the Nozzle with one steady and smooth movement. **Hold the Nozzle Actuator back during the entire disconnection process.**

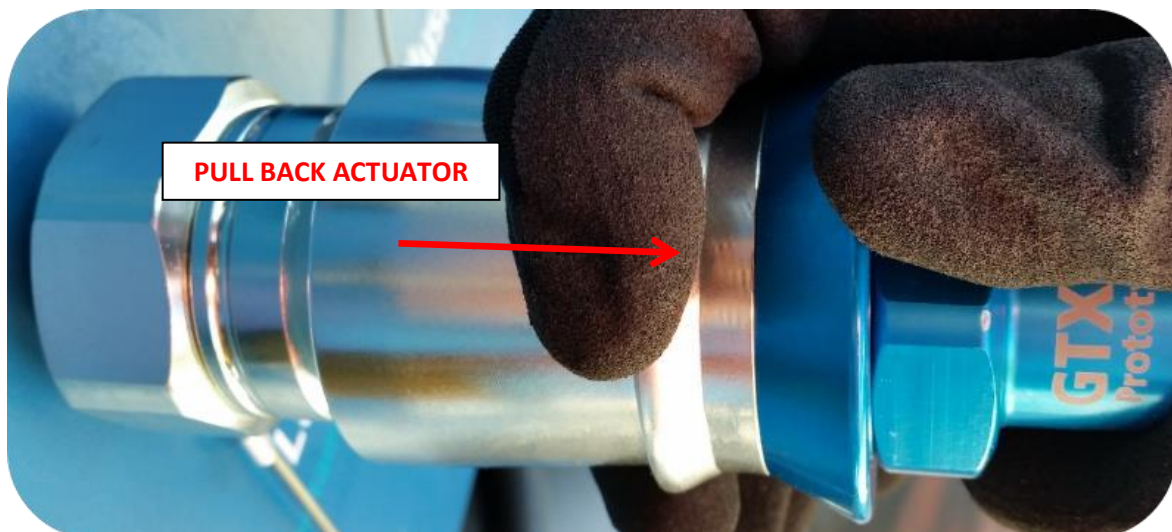

**Figure 8 - Disconnecting the Couplers - Retract Actuator**

14. Once disengaged, release Actuator. Ensure both the Nozzle and Receiver return to their “normally closed” (sealed) state. If not, repeat (only) steps 7, 8, 9 and 12. If either coupler still fails to close, promptly replace faulty Coupler or place this grease point “Out of Service” to prevent further use.
15. **Replace** the Receiver Dust Cap, and **close** the bleed valve (or bleed system) at the Receiver outlet.
16. Replace the Nozzle Dust Cap (if fitted) and safely return the Nozzle etc. by carrying them to their designated storage location, i.e. do **NOT** drag the Nozzle or Valve along the ground, or allow impact with any object.
17. **Ensure work area and all equipment are left clean and in a safe state.**

## 6.1 GTX Grease Coupler Operation Overview

- 1 ENSURE GREASE DISPENSING SYSTEM IS SAFE AND AVAILABLE FOR USE

---

- 2 CLOSE VALVE AT GTXN NOZZLE INLET

---

- 3 OPEN BLEED VALVE ON GTXR RECEIVER OUTLET TO BLEED PRESSURE TO "ZERO"

---

- 4 REMOVE RECEIVER DUST CAP (AND NOZZLE DUST CAP IF FITTED)

---

- 5 WIPE FRONT OF EACH COUPLER CLEAN WITH RAG

---

- 6 FULLY (CONCENTRICALLY) ALIGN GTXN NOZZLE WITH GTXR RECEIVER

---

- 7 HOLDING ONLY THE NOZZLE "TAIL", PUSH ONTO RECEIVER UNTIL FULLY CONNECTED

---

- 8 PULL BACK ON NOZZLE "TAIL" TO ENSURE SECURE CONNECTION

---

- 9 CLOSE BLEED VALVE AT GTXR RECEIVER OUTLET

---

- 10 OPEN VALVE AT NOZZLE INLET AND START GREASE DISPENSING PUMP

---

- 11 COMPLETE THE REQUIRED GREASE TRANSFER

---

- 12 TURN OFF GREASE DISPENSING PUMP THEN CLOSE VALVE AT NOZZLE INLET

---

- 13 OPEN BLEED VALVE ON GTXR RECEIVER OUTLET TO BLEED PRESSURE TO "ZERO"

---

- 14 HOLDING WEIGHT OF NOZZLE, RETRACT NOZZLE ACTUATOR and DISCONNECT COUPLERS

---

- 15 CLOSE BLEED VALVE ON RECEIVER OUTLET

---

- 16 REPLACE DUST CAP(S)

---

- 17 RETURN NOZZLE AND ATTACHED EQUIPMENT TO STORAGE LOCATION

---

- 18 ENSURE THE GREASE DISPENSING SYSTEM AND WORK AREA ARE LEFT IN A SAFE STATE

---

## 7 MAINTENANCE GUIDELINES

This Maintenance Guide is general, and is not meant to replace or override maintenance guidelines that arise out of a *due diligence* assessment of the Banlaw GTX series Grease Couplers for a specific grease transfer application. For more detailed advice please contact Banlaw or your nearest authorised Banlaw distributor.

The following *preventative maintenance* guidelines apply to the GTX Couplers;

- Inspect GTX Couplers and other grease dispensing equipment prior to use for damage, excessive leakage or some other defect which may affect the safe use of the dispensing system.
- **Do NOT store the GTXN Nozzle laying on the ground, or otherwise in an area prone to excessive contamination or possible damage.** Ensure there is provision to safely store the Nozzle and attached grease dispensing hose away from plant equipment or operator (human) thoroughfares.
- **Prior** to use, wipe away residual grease and contamination from all mating surfaces of the GTX couplers. This will not only reduce the ingress of contamination into the grease stream, but also help to avoid accelerated wear and tear of the couplers.
- To further reduce contamination, use the Coupler Dust Caps – e.g. Figure 9. The use of Dust Caps will also reduce the risk of damage to a Coupler from impact when not in use.



Figure 9 - Receiver Dust Cap (GTXRCC)

- **Closely** inspect the front area of the GTXR Receiver, including the ball lock groove (refer Figure 10), for signs of damage or excessive wear and tear. Excessive wear or damage may cause problems connecting and disconnecting the GTX couplers, but will also introduce the risk of unintentional coupler disconnection – i.e. GTXN Nozzle “fly off” – during grease transfer. Promptly replace any faulty GTX couplers prior to their next required use, or place the coupler(s) “Out of Service” until replacement.

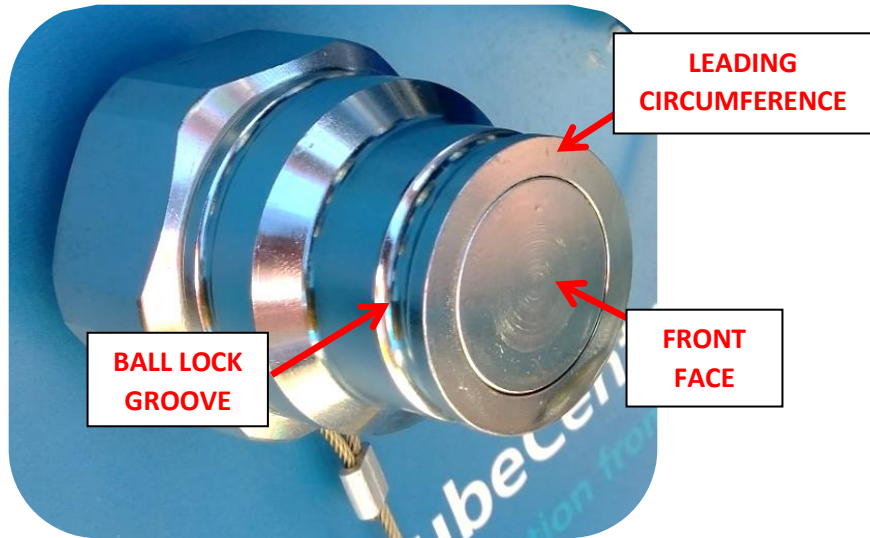

Figure 10 - Critical Areas of Damage on GTXR Receivers

7.1 GTX Coupler Spare Parts

The Banlaw GTX series Grease Couplers are **non-serviceable** items. The following genuine Banlaw spare parts are available to suit this product. **The use of non-genuine parts, or the dismantling, misuse or tampering of this product may cause improper and unsafe function, serious safety hazards, and void Banlaw warranty.** Please see [www.banlaw.com](http://www.banlaw.com) for warranty details and a full list of distributors near your area to source genuine Banlaw replacement spares and new products.

Item Description	Banlaw Part Number
Receiver Dust Cap	GTXRCC
Receiver Dust Cap (Arctic)	GTXRCC-CT

Table 3 - GTX Spare Parts

END OF DOCUMENT



**BANLAW – UNIFIED FUEL MANAGEMENT**

BANLAW OFFICES

AUSTRALIA / PACIFIC		AMERICAS / INTERNATIONAL	
<b>HEAD OFFICE</b>	<b>WESTERN AUSTRALIA</b>	<b>NORTH AMERICA</b>	
Phone +61 2 4922 6300	Phone +61 8 9209 1351	Phone 1 385 259 0456	
Fax +61 2 4920 6171	Fax +61 8 9209 1616	Email <a href="mailto:americasales@banlaw.com">americasales@banlaw.com</a>	
Email <a href="mailto:sales@banlaw.com">sales@banlaw.com</a>	Email <a href="mailto:sales@banlaw.com">sales@banlaw.com</a>	537 West 600 South #800	
19 Metro Court	1/16 Oxleigh Drive	Salt Lake City	
Gateshead NSW 2290	Malaga WA 6090	Utah 84101	
Australia	Australia	USA	

Website – [www.banlaw.com](http://www.banlaw.com)